

KA326400TX

Barksdale 3pc Breakfast Set

Assembly Instructions



Southern  
ENTERPRISES

For assistance with assembly, contact:  
Southern Enterprises, Inc.  
Customer Service: 1-800-633-5096  
service@seidal.com  
[www.seifurniturestore.com](http://www.seifurniturestore.com)

**PO:**

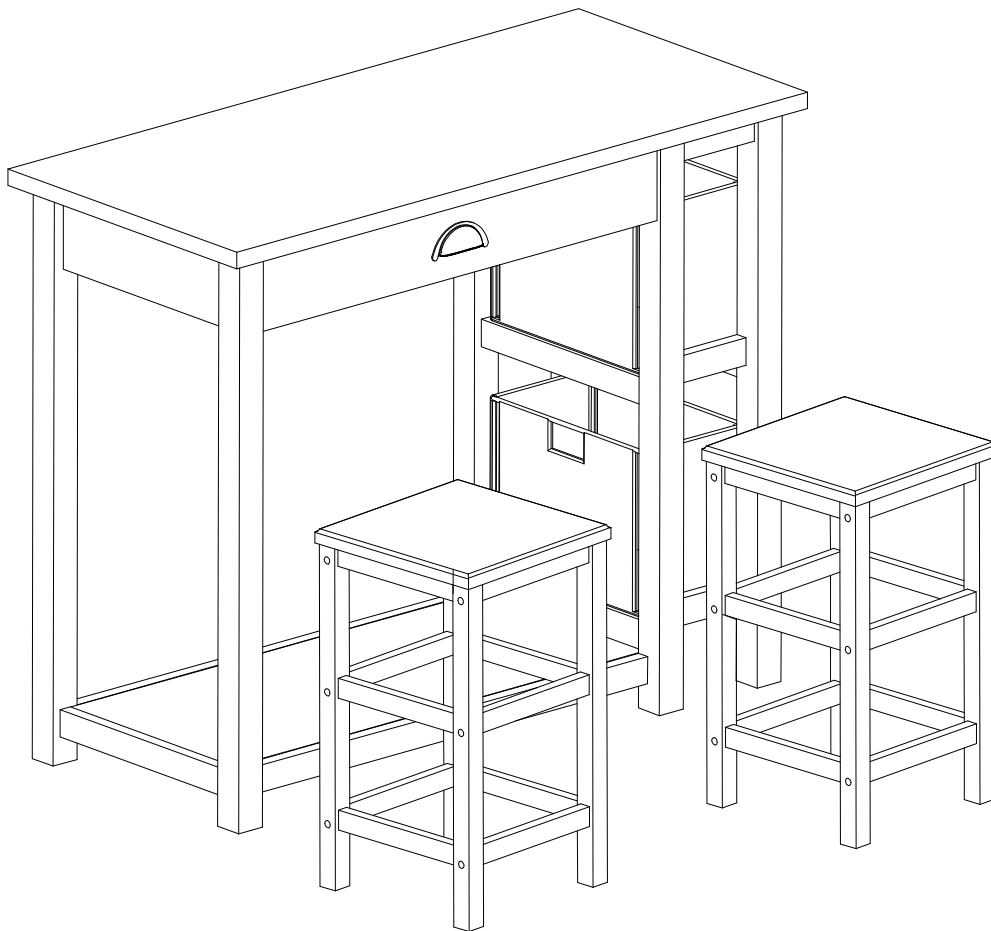



# Barksdale 3pc Breakfast Set

## Parts List

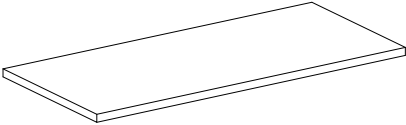
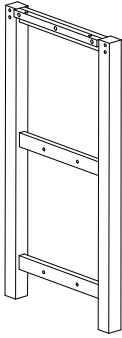
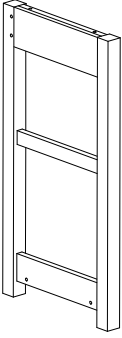
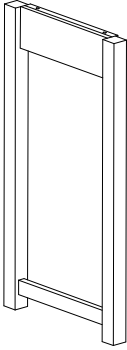
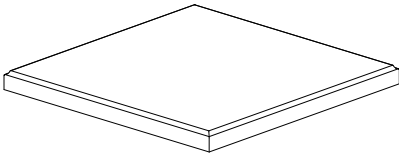
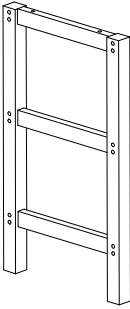
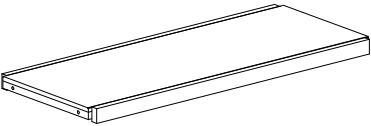
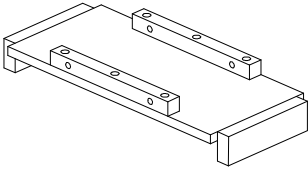
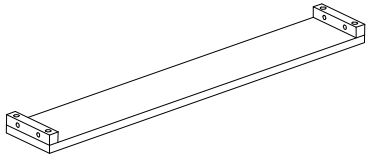
Please check packaging for all parts and hardware before discarding. Unpack and lay parts on clean, padded surface like carpet or a blanket. Check that you have all parts indicated. Call customer service if any hardware is missing. Before beginning assembly, carefully study the diagrams below and sort your hardware according to the pictures. Using the incorrect hardware will cause damage.

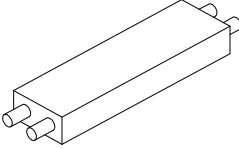
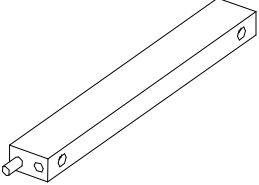
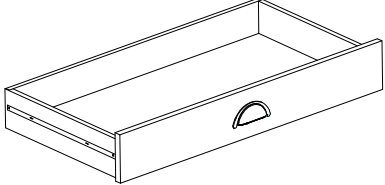
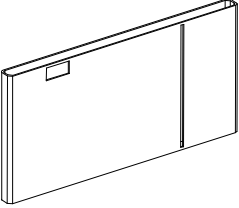
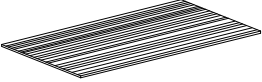
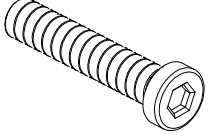
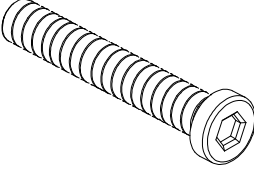
<p><b>A</b> Quantity of 1</p>  <p>Top Panel</p>	<p><b>B</b> Quantity of 1</p>  <p>Right Side Frame</p>	<p><b>C</b> Quantity of 1</p>  <p>Center Frame</p>
<p><b>D</b> Quantity of 1</p>  <p>Left Side Frame</p>	<p><b>E</b> Quantity of 2</p>  <p>Seat Panel</p>	<p><b>F</b> Quantity of 4</p>  <p>Stool Side Frame</p>
<p><b>G</b> Quantity of 1</p>  <p>Bottom Panel</p>	<p><b>H</b> Quantity of 2</p>  <p>Fixed Shelf</p>	<p><b>I</b> Quantity of 1</p>  <p>Back Panel</p>

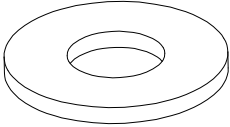
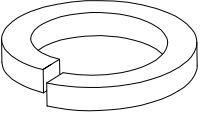
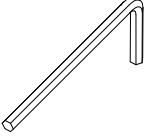
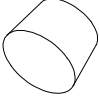
<p><b>J</b> Quantity of 2</p>  <p>Connecting bar</p>	<p><b>K</b> Quantity of 12</p>  <p>Stool Side rail</p>	<p><b>L</b> Quantity of 1</p>  <p>Drawer</p>
<p><b>M</b> Quantity of 2</p>  <p>Basket Frame</p>	<p><b>N</b> Quantity of 2</p>  <p>Basket Bottom Panel</p>	<p><b>1</b> Quantity of 22</p>  <p>Short Bolt <math>\backslash \Phi 1/4" * 1-1/4" L</math></p>
<p><b>2</b> Quantity of 32</p>  <p>Long Bolt <math>\Phi 1/4" * 1-1/2" L</math></p>	<p><b>3</b> Quantity of 24</p>  <p>Nut</p>	<p><b>4</b> Quantity of 22</p>  <p>Flat Washer</p>
<p><b>5</b> Quantity of 22</p>  <p>Spring Washer</p>	<p><b>6</b> Quantity of 1</p>  <p>Allen Wrench</p>	<p><b>7</b> Quantity of 24</p>  <p>Wood Plug</p>
<p><b>Care and Cleaning Instructions:</b> Before using, wipe with a clean, dry cloth. Avoid rubbing or scratching the surface with rough or abrasive objects.</p>		<p>For replacement parts or questions, please call SEI customer service at 1-800-633-5096.</p>

# Barksdale 3pc Breakfast Set Assembly Instructions

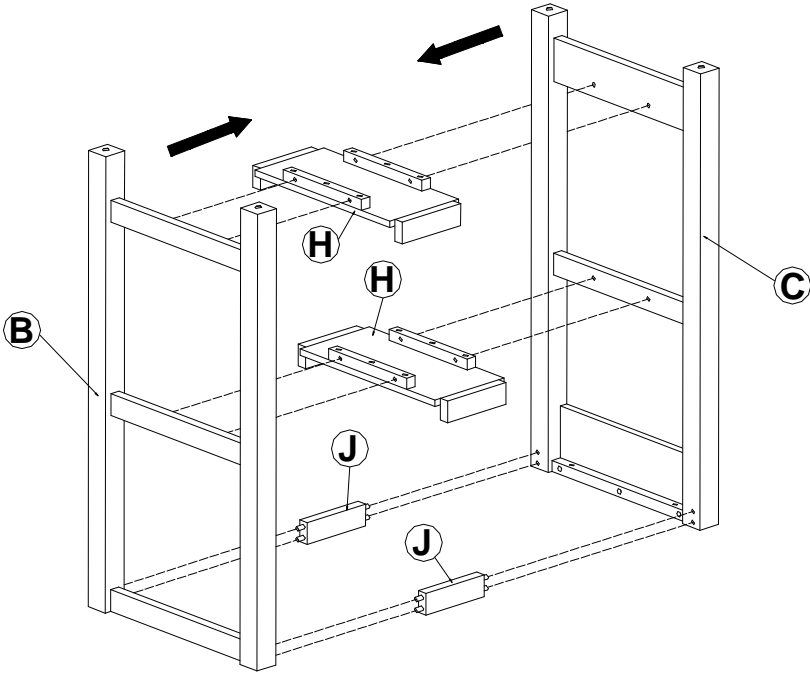

Line up Right Side Frame (B) and Center Frame (C) to Fixed Shelves (H) and Connecting Bars (J).

**Figure 1**

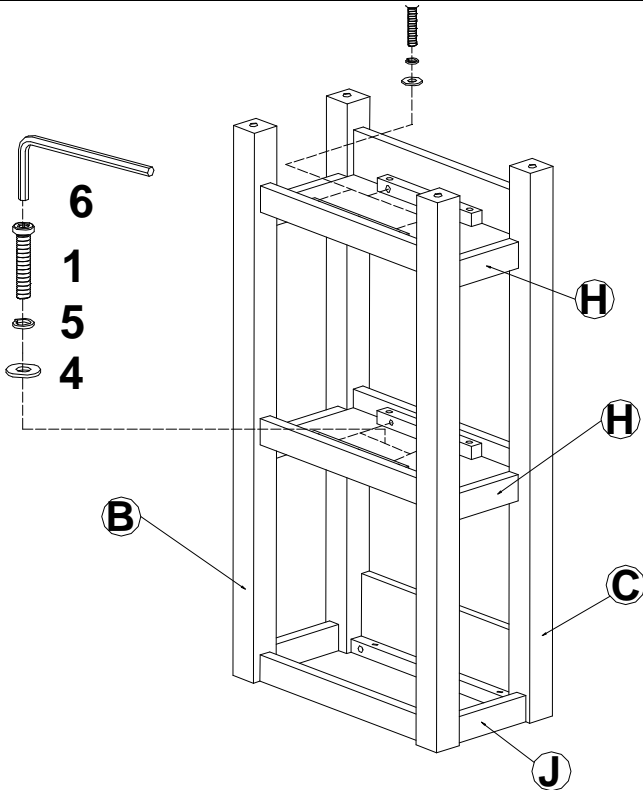

Secure Center Frame (C) and Right Side Frame (B) to Fixed Shelves (H) using Short Bolts (1), Spring Washers (5), and Flat Washers (4).

Tighten Bolts (1) with Allen Wrench (6)

**Figure 2**

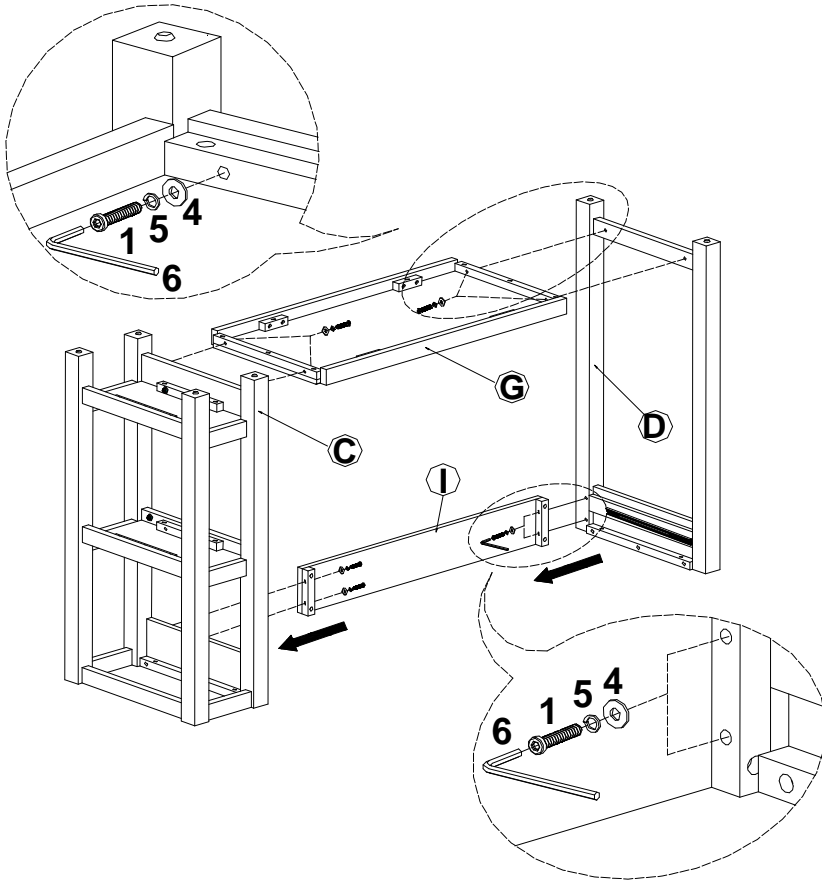

**Figure 3**

Attach the assembled unit to Bottom Panel **(G)**, Left Side Panel **(D)**, and Back Panel **(I)** using Short Bolts **(1)**, Spring Washers **(5)**, and Flat Washers **(4)**.

Tighten Bolts **(1)** with Allen Wrench **(6)**.

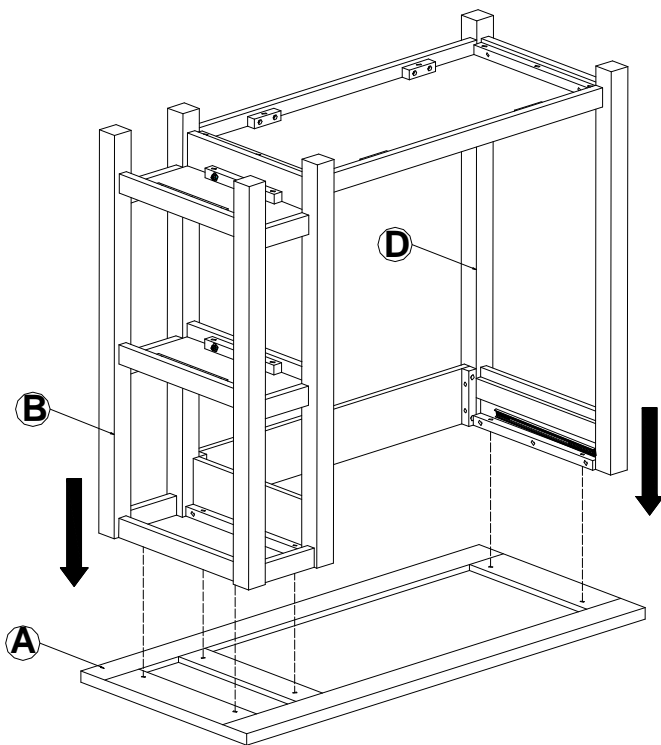

**Figure 4**

Line up the assembled unit with Top Panel **(A)**.

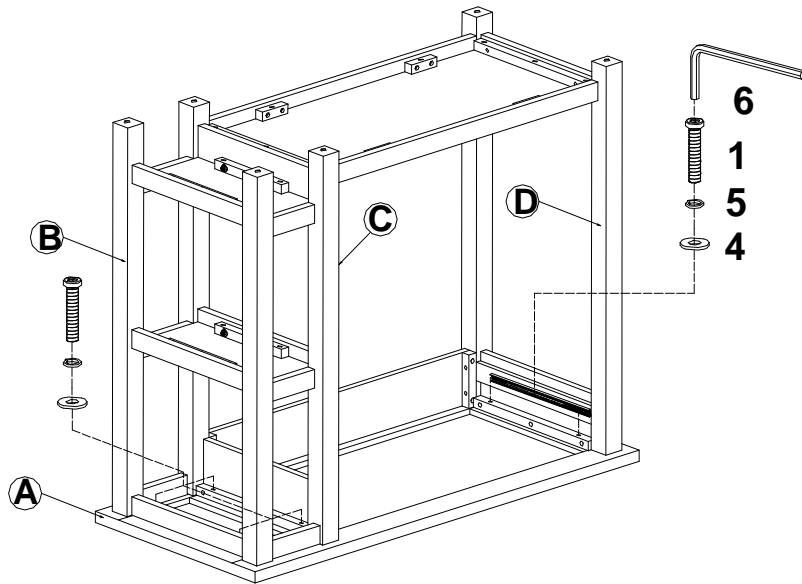

Attach assembled unit to Top Panel (A) using Short Bolts (1), Spring Washers (5), and Flat Washers (4).

Tighten Bolts (1) with Allen Wrench (6).

Figure 5

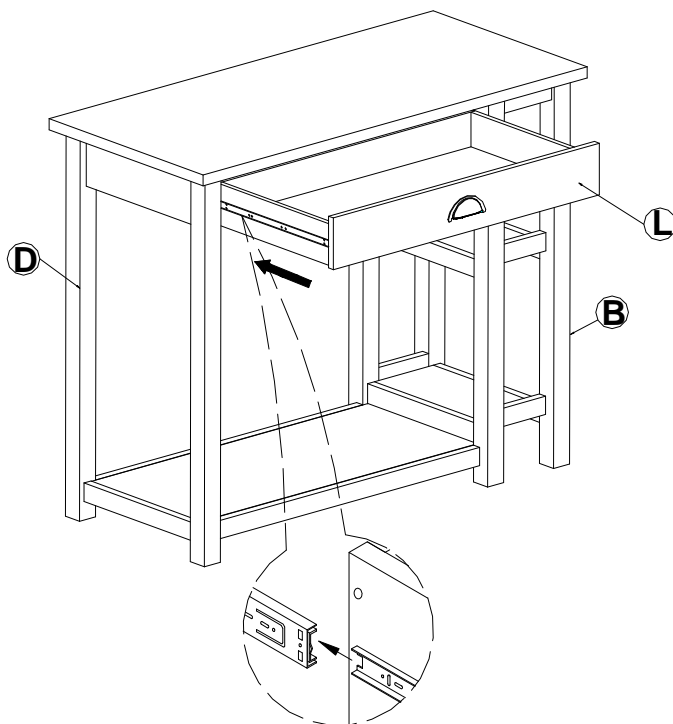

Turn the assembled table over.

Insert pre-assembled drawer (L).

Make sure drawer smoothly slides in and out.

Figure 6

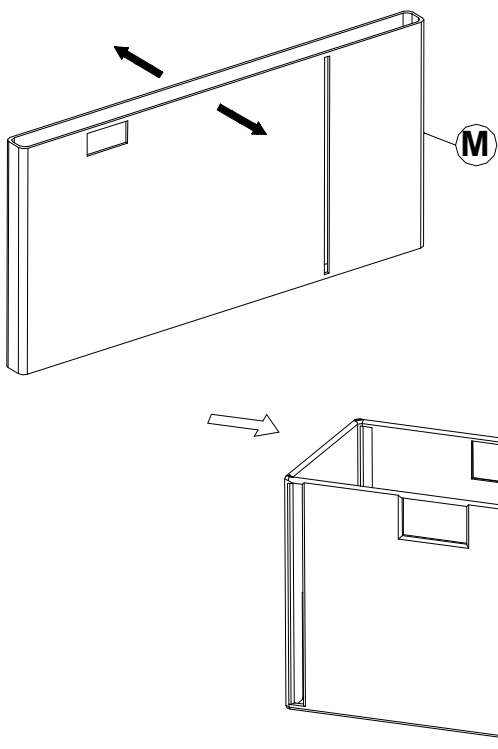

Open the folding Basket Frame **(M)**.

**Figure 7**

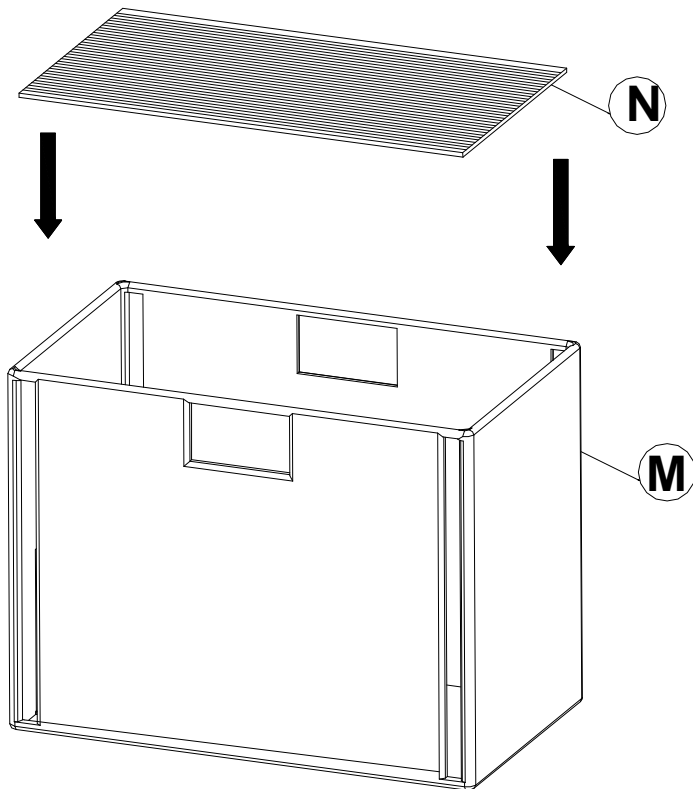

Insert Basket Bottom panel **(N)** into Basket Frame **(M)**.

**Figure 8**

Place the assembled baskets on Fixed Shelves (H).

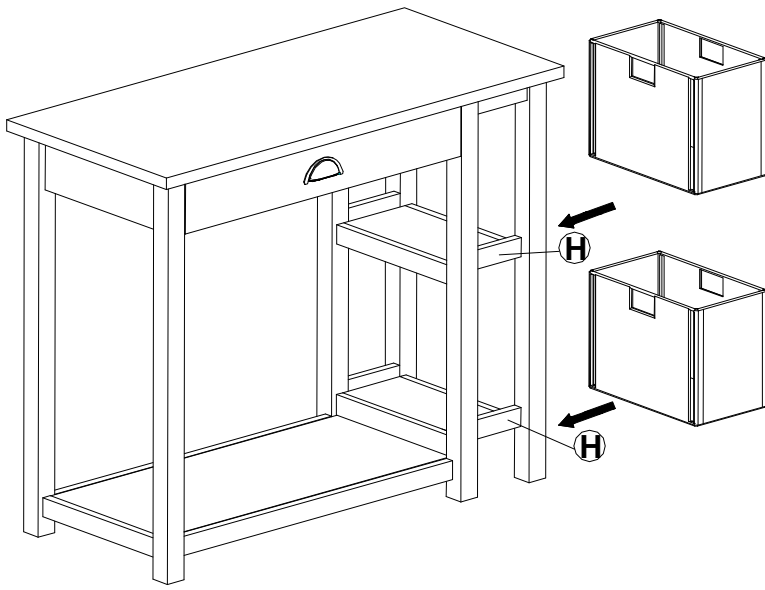

**Figure 9**

Now the table is ready to use.

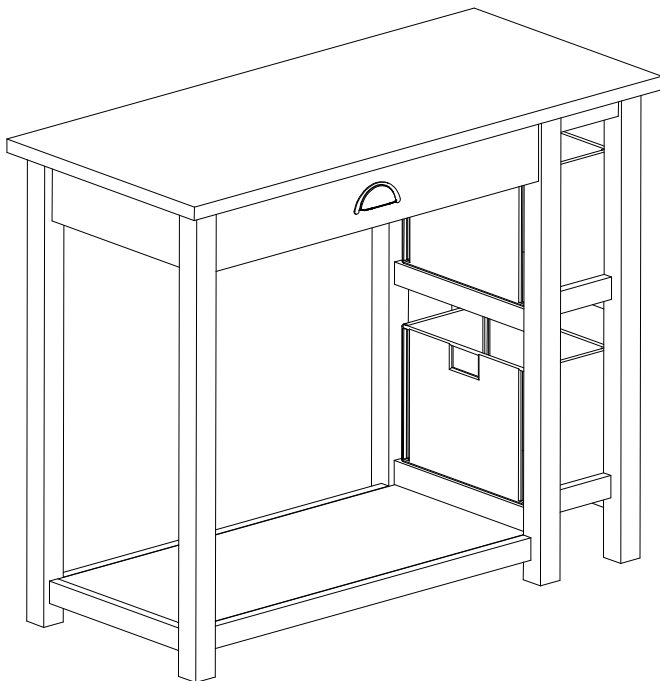

**Figure 10**



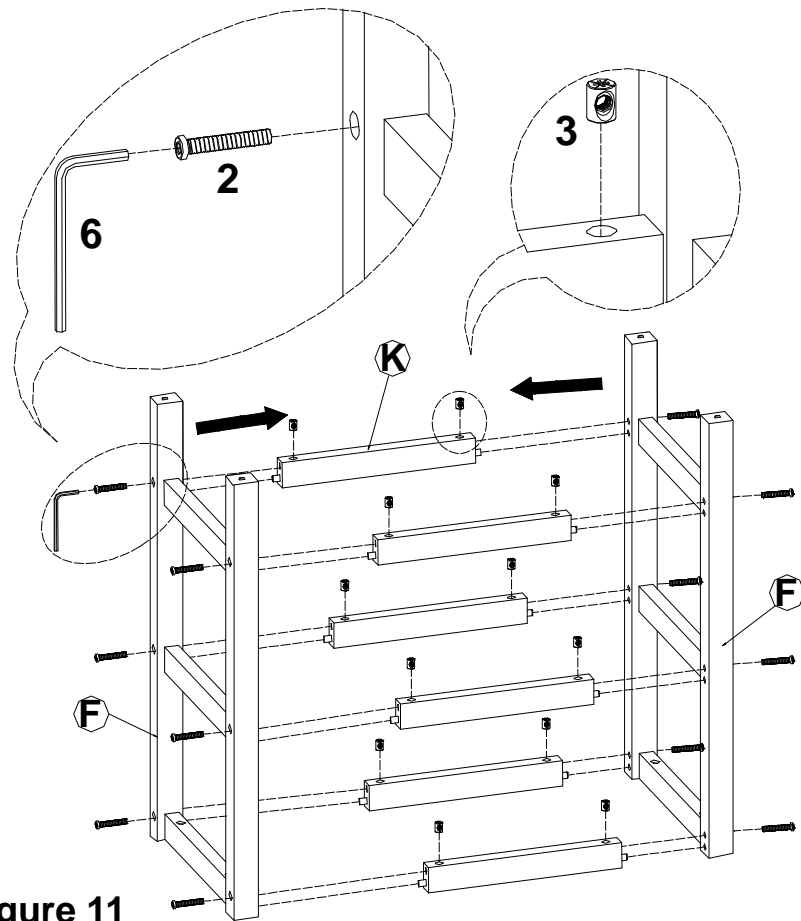

Figure 11

Attach Stool Side Frames (**F**) to Stool Side Rails (**K**).

Insert Nuts (**3**) into pre-drilled holes on Stool Side Rails (**K**).

Insert Long Bolts (**2**) through pre-drilled holes on Stool Side Frames (**F**) into Nuts (**3**).

Tighten Long Bolts (**2**) with Allen Wrench (**6**).

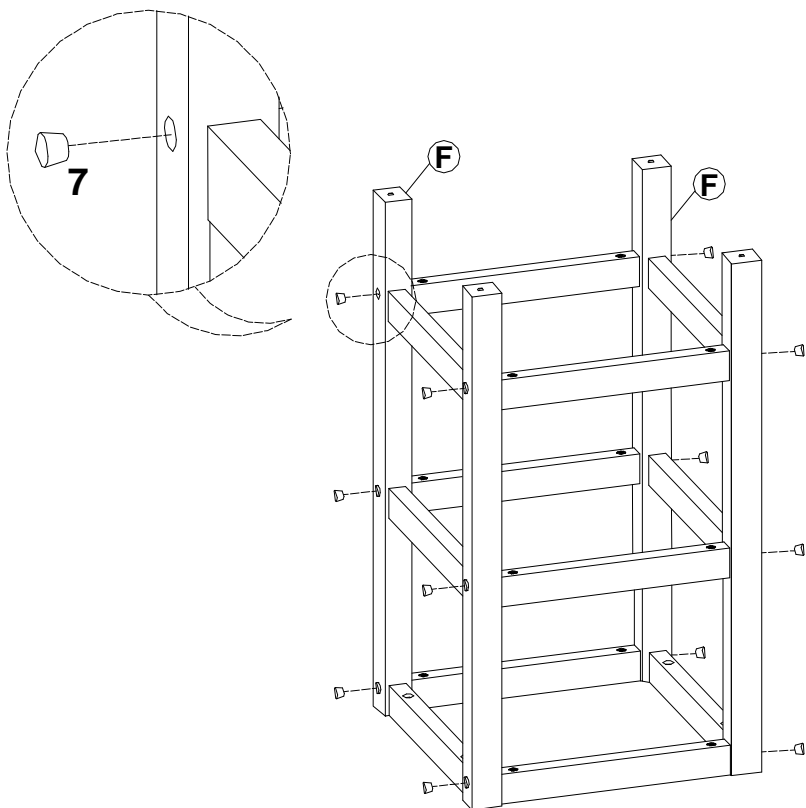
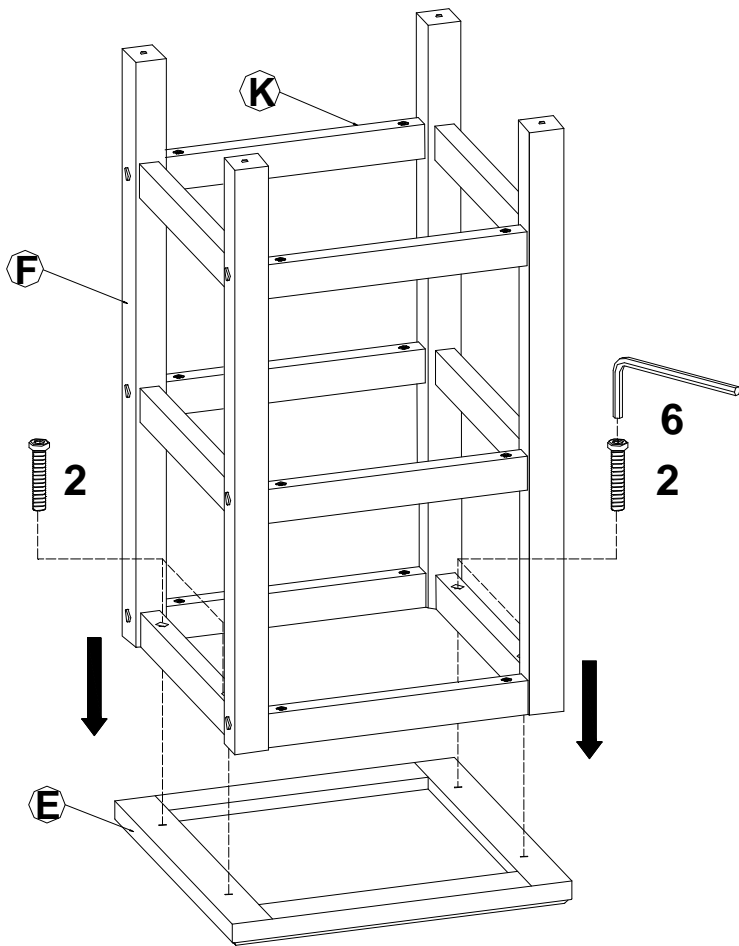

Figure 12

Cover the holes on Stool Side Frames (**F**) using Wood Plugs (**7**).



**Figure 13**

Attach the assembled unit to Seat Panel **(E)**, using Long Bolts **(2)**.

Tighten Bolts **(2)** with Allen Wrench **(6)**

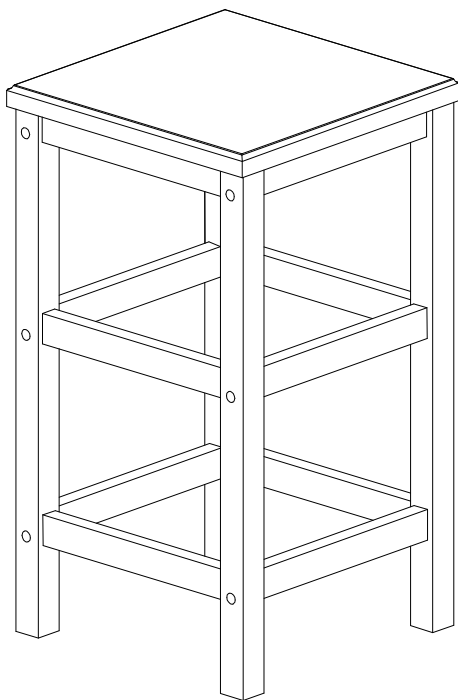
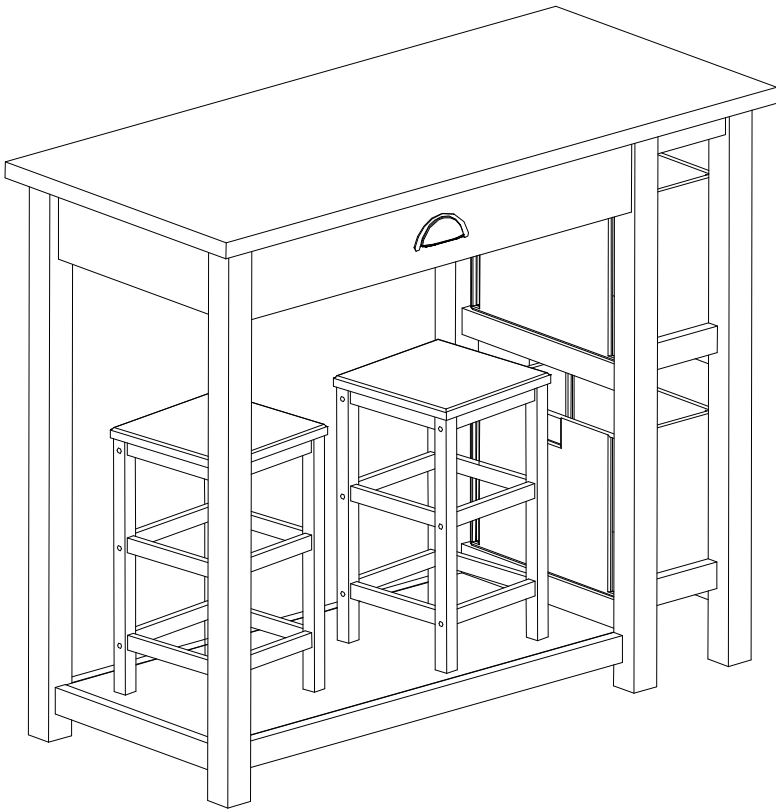

**Figure 14**

Turn the assembled stool over and it is ready to use.

Repeat steps 11-14 for 2<sup>nd</sup> stool.

When desired, place assembled stools under assembled table for storage.



**Figure 15**

# Parts Replacement Form

## Customer Information

Name \_\_\_\_\_

Address \_\_\_\_\_

City/State/Zip Code \_\_\_\_\_

Phone Number \_\_\_\_\_

Please indicate where you purchased this item: Store/Website/Catalog

\_\_\_\_\_

Please indicate color/style number:

\_\_\_\_\_

Style No	Parts Letter	Parts Description	Quantity Needed
_____	_____	_____	_____
_____	_____	_____	_____
_____	_____	_____	_____

Please immediately examine this product carefully. Any request for missing parts or damage replacement must be received within 90 days of your receipt of the product. Replacement, if available, will be honored within this time frame. Parts will not be available for items arriving fully assembled. We do not recommend modifying product(s) and we are not responsible for any damages due to product modification(s). If damages or missing parts are not reported within 90 days of your receipt, we are under no obligation to provide parts or replacement merchandise.

For product issues, please contact Southern Enterprises at 800-633-5096 (toll-free) / 972-869-0111 (Dallas), Mon-Fri 9am – 4pm CST, or email us at [service@seidal.com](mailto:service@seidal.com). Please ask for customer service representative for issues involving damages or replacement parts. Please ask for technical assistance representative for any issues with product and assembly/construction.

Please contact the retailer that you purchased from for return



**Southern**  
ENTERPRISES

Customer Service: 1-800-633-5096  
[service@seidal.com](mailto:service@seidal.com)

Southern Enterprises, Inc.  
600 Freeport Parkway, Suite 200  
Coppell, Texas 75019