

HZ201900TX

Kersey Bar Cart

Assembly Instructions



Southern
ENTERPRISES

For assistance with assembly, contact:
Southern Enterprises Inc.
Customer Service: 1-800-633-5096
service@seidal.com
www.seidal.com

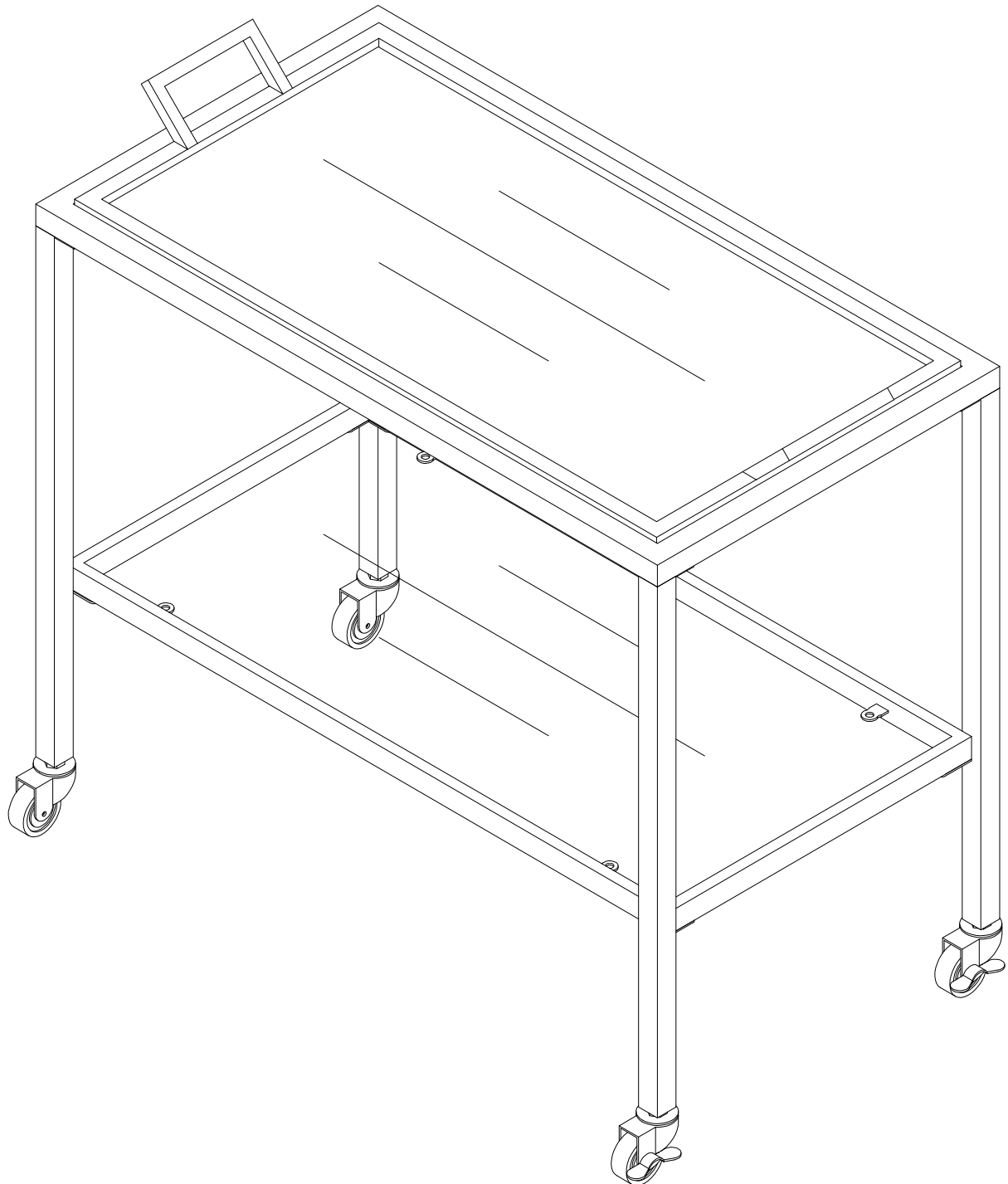





Kersey Bar Cart

Parts List

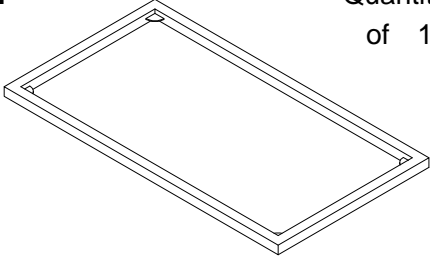
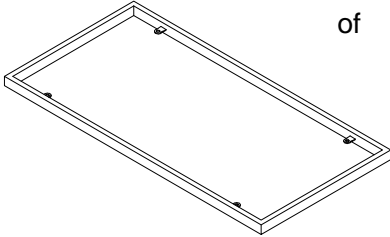
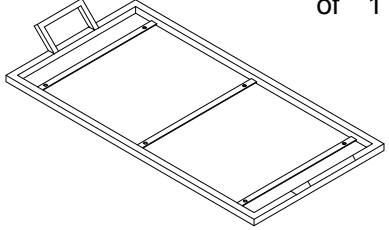
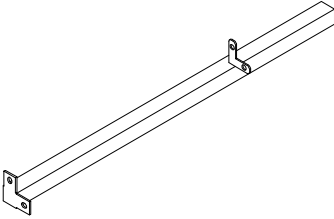
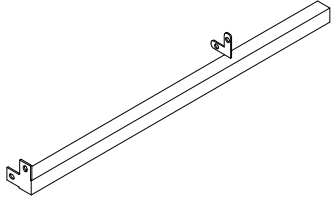
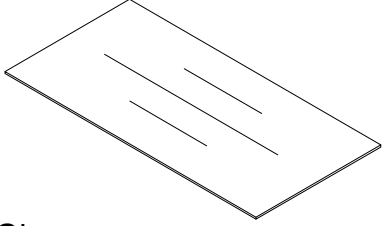
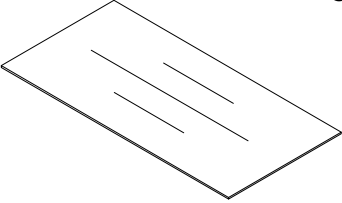
Please review all parts and hardware before disposing of any packaging.

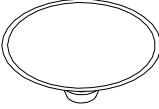
Before beginning assembly, separate each type of hardware. Carefully study the diagrams below and check that you have all parts indicated. Call Customer Service if missing hardware. Using the incorrect hardware will cause damage. You may receive extra hardware with your unit.

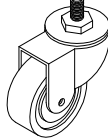
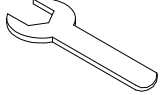
<p>A. Quantity of 1</p>  <p>Top Frame</p>	<p>B. Quantity of 1</p>  <p>Bottom Frame</p>	<p>C. Quantity of 1</p>  <p>Tray Frame</p>
<p>D. Quantity of 2</p>  <p>Left Legs</p>	<p>E. Quantity of 2</p>  <p>Right Legs</p>	<p>F. Quantity of 1</p>  <p>Glass</p>
<p>G. Quantity of 1</p>  <p>Mirror</p>		
<p>1. Quantity of 16</p>  <p>Bolts: Dia1/4"x1/2"</p>	<p>2. Quantity of 10</p>  <p>Glass Pads</p>	<p>3. Quantity of 1</p>  <p>Allen Wrench Dia1/4"</p>
<p>4. Quantity of 2</p>  <p>Brake Casters</p>	<p>5. Quantity of 2</p>  <p>Casters</p>	<p>6. Quantity of 1</p>  <p>Wrench</p>

Care and Cleaning Instructions:

Before using, wipe with a clean, dry cloth. Periodically apply furniture wax to renew the finish. Avoid rubbing or scratching the surface with rough or abrasive objects.

Call customer service at 1-800-633-5096 for assistance, questions, or parts.

Kersey Bar Cart

Assembly Instructions

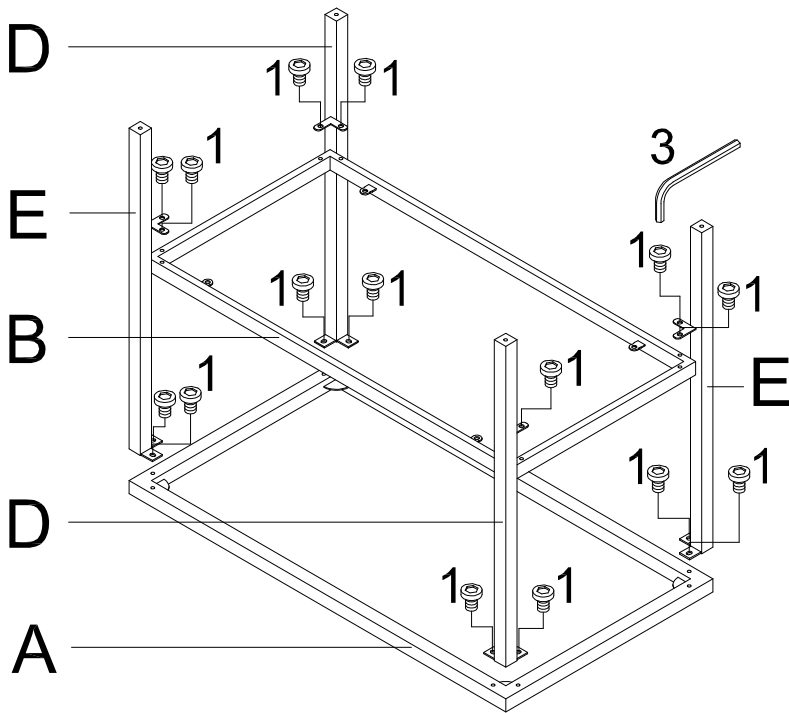

Start screwing with fingers to help align bolts before using Allen Wrench.

Attach Legs (D/E) to Top Frame (A) with Bolts (1) as shown.

Attach Bottom Frame (B) to underside of tabs on Legs (D/E) with Bolts (1).

Tighten Bolts (1) with Allen Wrench (3).

Figure 1

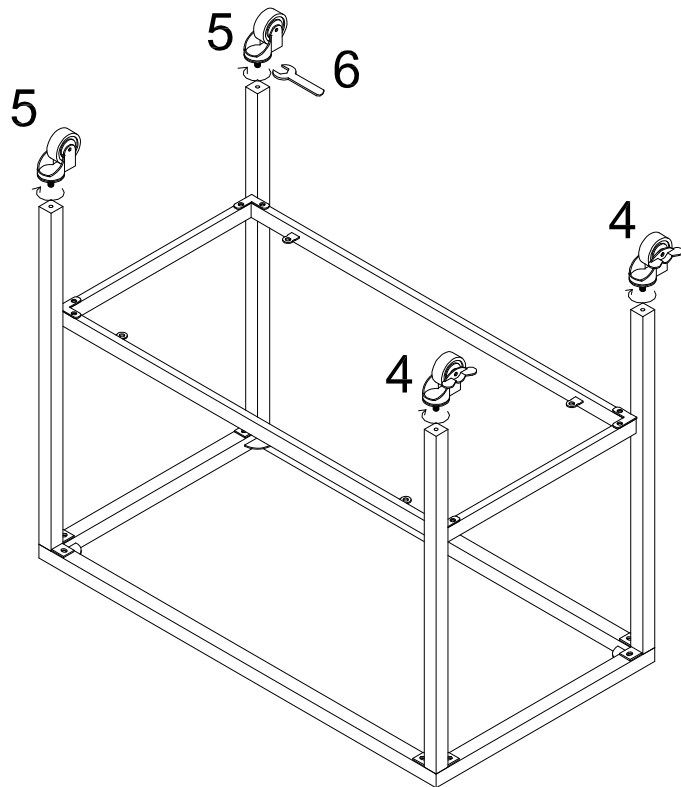

Attach Casters (4/5) to assembled unit from Figure 1 by hand.

Tighten Casters (4/5) with Wrench (6).

Figure 2

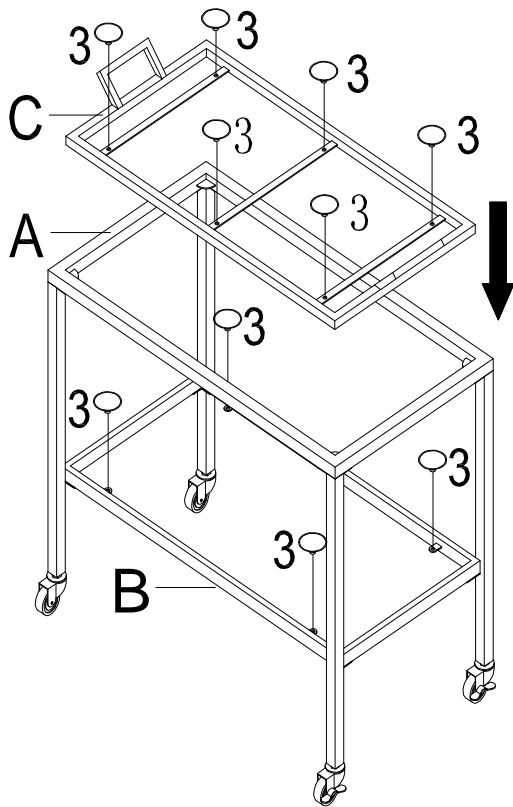

Place Tray Frame (C) on top of assembled unit from Figure 2.

Insert Glass Pads (3) into Tray Frame (C) and Bottom Frame (B) by hand.

Figure 3

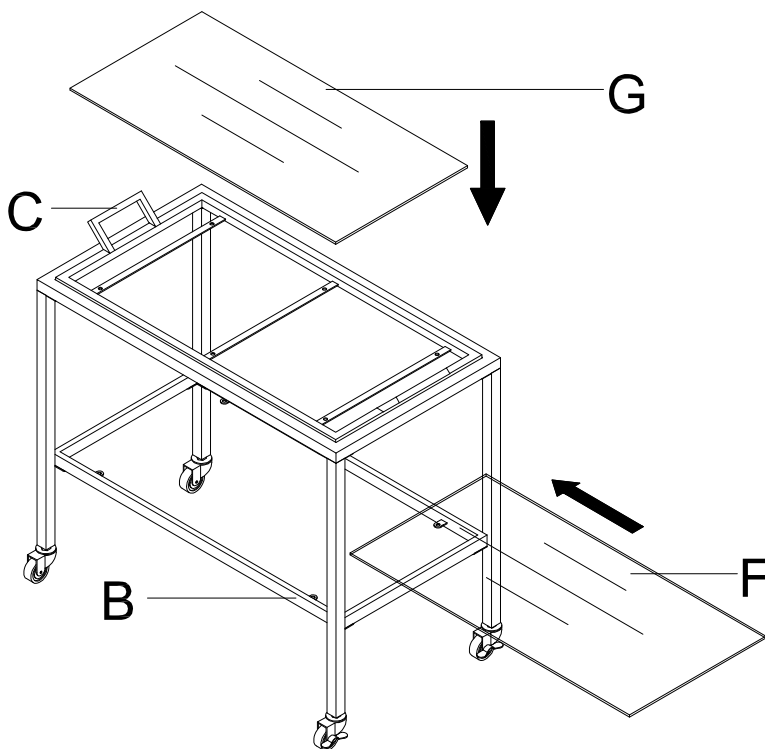

Place Mirror (G) onto Tray Frame (C).

Place Glass (F) onto Bottom Frame (B).

Figure 4

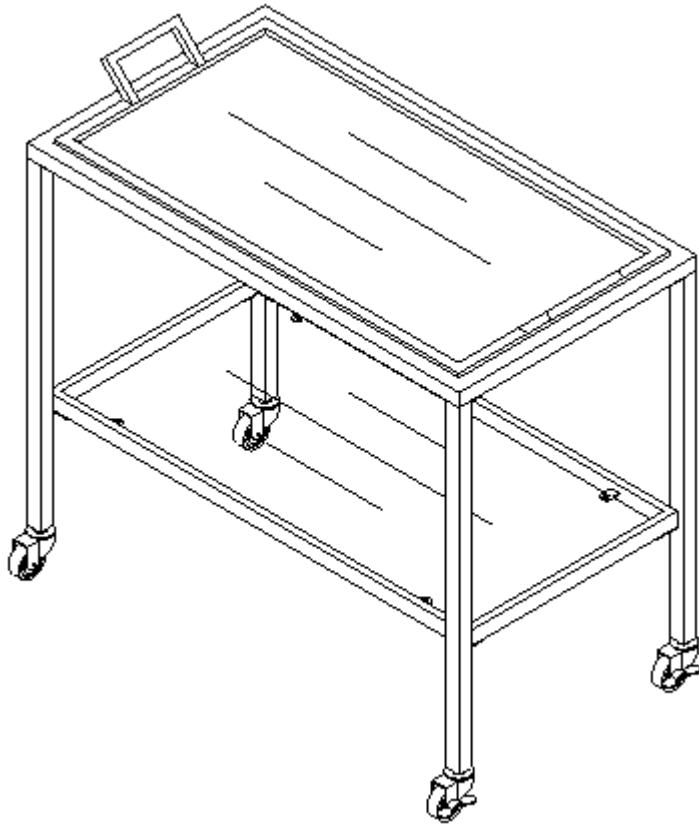

Now your Kersey Bar Cart is ready for use!

Figure 5

Parts Replacement Form

Customer Information

Name _____

Address _____

City/State/Zip Code _____

Phone Number _____

Please indicate where you purchased this item: Store/Website/Catalog

Please indicate color/size/style number:

Style No	Parts Letter	Parts Description	Quantity Needed
_____	_____	_____	_____
_____	_____	_____	_____
_____	_____	_____	_____

Please immediately examine this product carefully. Any request for missing parts or damage replacement must be received within 90 days of your receipt of the product. Replacement, if available, will be honored within this time frame. Parts will not be available for items arriving fully assembled. We do not recommend modifying product(s) and we are not responsible for any damages due to product modification(s). If damages or missing parts are not reported within 90 days of your receipt, we are under no obligation to provide parts or replacement merchandise.

For product issues, please contact Southern Enterprises at 800-633-5096 (toll-free) / 972-869-0111 (Dallas), Mon-Fri 9am – 4pm CST, or email us at service@seidal.com. Please ask for customer service representative for issues involving damages or replacement parts. Please ask for technical assistance representative for any issues with product and assembly/construction.

Please contact the retailer that you purchased from for returns.



Southern
ENTERPRISES

Customer Service: 1-800-633-5096
service@seidal.com

Southern Enterprises, Inc.
600 Freeport Parkway, Suite 200
Coppell, Texas 75019