

EN810100TX

Aspen Floating Shelf 10" Chocolate

EN810200TX

Aspen Floating Shelf 10" Black

Assembly Instructions



**Southern
ENTERPRISES**

For assistance with assembly contact:

Southern Enterprises Inc.

Customer Service 1-800-633-5096

service@seidal.com

www.seidal.com

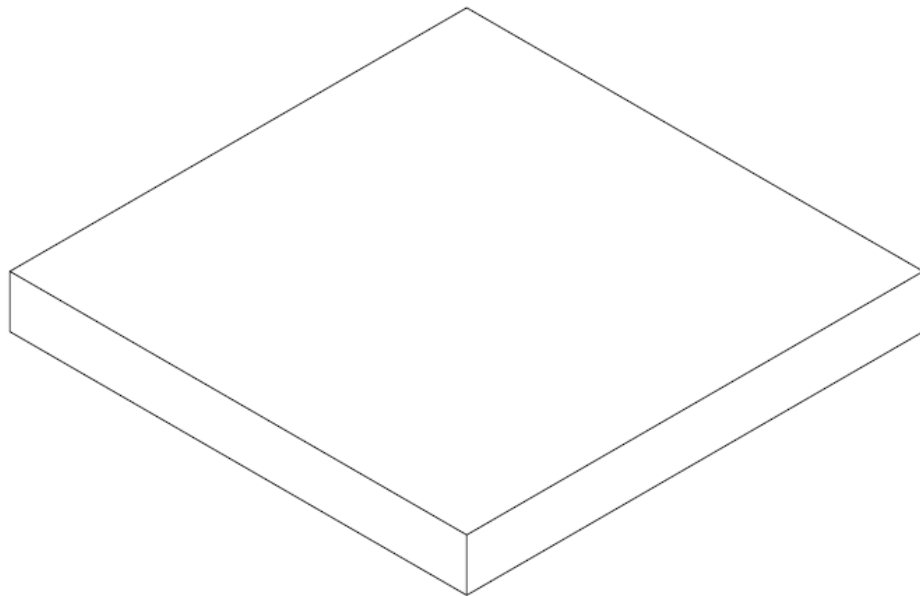

Max loading weight: 20lbs

Aspen Floating Shelf 10"

Parts List

Please check packaging for all parts and hardware before discarding. Unpack and lay parts on clean, padded surface like carpet or blanket. Check that you have all parts indicated. Call customer service if hardware is missing. Before beginning assembly, carefully study the diagrams below and sort your hardware according to the pictures.

Using the incorrect hardware will cause damage.

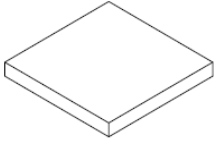
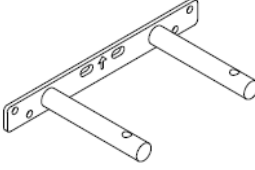
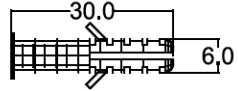
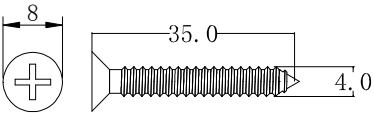
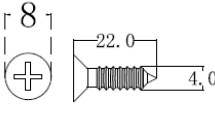
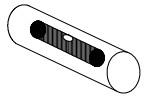
A  Shelf	Quantity: 1	B  Bracket packed on back edge of shelf	Quantity: 1	C  Plastic anchor: 6 x 30mm	Quantity: 5
D  Screw: 8 x 35mm	Quantity: 5	E  Screw: 8 x 22mm	Quantity: 2	F  Level	Quantity: 1

Care and Cleaning Instructions:
 Before using, wipe with a clean, dry cloth. Periodically apply furniture wax to renew the finish. Avoid rubbing or scratching the surface with rough or abrasive objects. For replacement parts or questions, please

Call customer service at 1-800-633-5096 for assistance, questions, or parts.

Assembly Tool Required (Not Included)

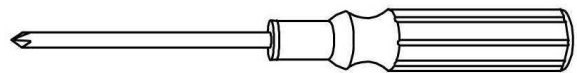

Suggested tools as below list

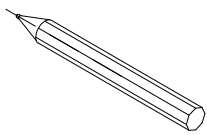
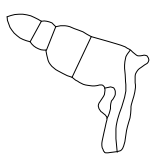
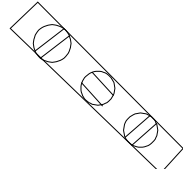
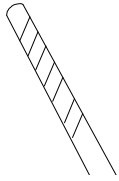
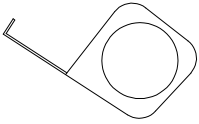
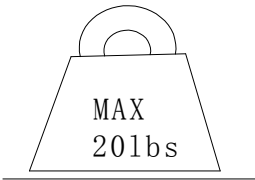
 Pencil	 Power drill	 Level
 Bit $\phi 3/16''$	 Tape measure	 MAX 20lbs capacity

Aspen Floating Shelf 10"

Assembly Instructions

Figure 1

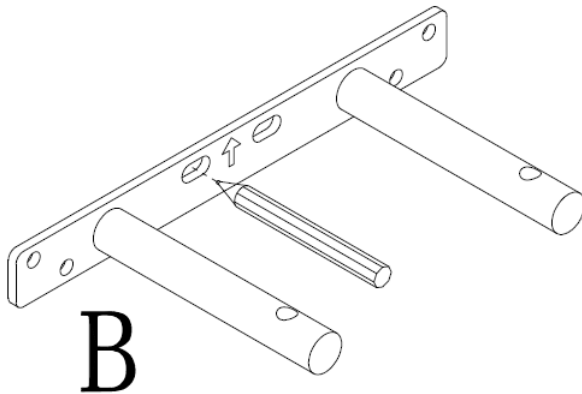

Important note: please remove Bracket "B" on back edge of shelf first.

Place the Mounting Bracket (B) against wall at desired location with arrow pointing up.

Place level on top of bracket to insure bracket is level. Mark each hole with a pencil.

Remove bracket.

Tip: If mounting to sheet rock (cavity wall) it is advisable to mount at least one screw (without anchor) directly to a wall stud.

Figure 2

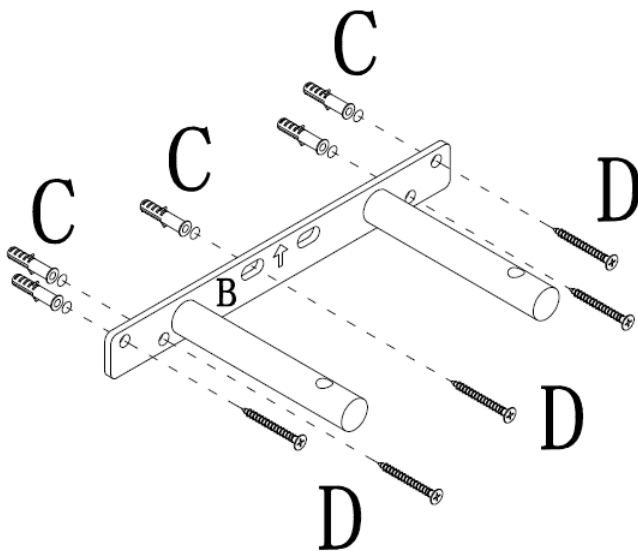

Using a power drill and 3/16" drill bit, drill a hole through wall at each marked location that is not a stud location.

Then, insert Plastic Anchors (C) into each hole and lightly tap Anchors (C) with a hammer until they are securely flush with face of wall.

After the Plastic Anchors (C) are securely in place, position Bracket (B) to be mounted to wall.

Using a Philips screwdriver, drive Screws (D) into Plastic Anchors (C) until Bracket (B) is securely placed on wall.

Drive a Screw (D) into a stud if applicable.

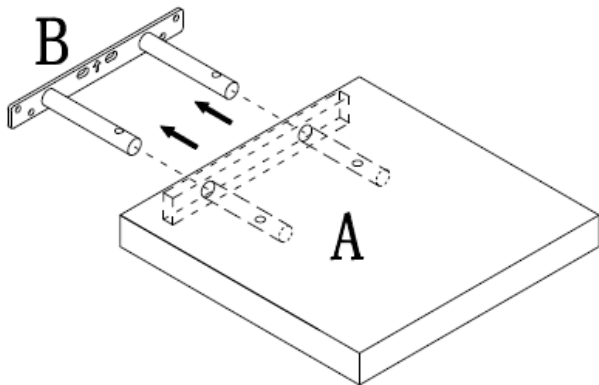

Slide the Shelf (**A**) onto Mounting Bracket (**B**) by aligning the two holes on Shelf (**A**) to poles on Bracket (**B**), making sure the two small holes are pointing down on bottom of Shelf (**A**).

Figure 3

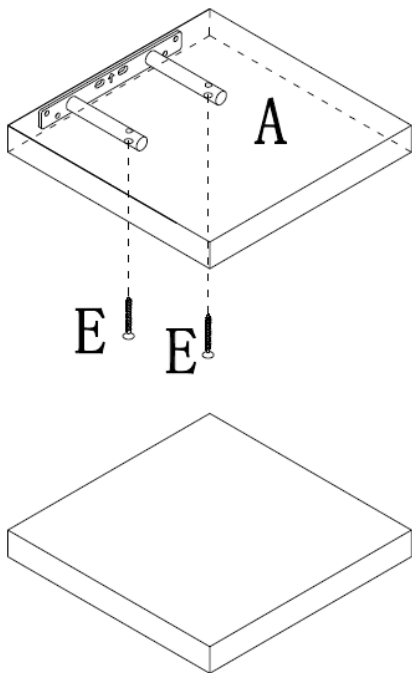

Insert two Long Screws (**E**) with a screwdriver to secure Shelf (**A**) to Bracket (**B**).

Place level on top to insure product is level.

Now your shelf is ready to use.

Figure 4

Parts Replacement Form

Customer Information

Name _____

Address _____

City/State/Zip Code _____

Phone Number _____

Please indicate where you purchased this item: Store/Website/Catalog

Please indicate color/size/style number:

Style No Needed	Parts Letter	Parts Description	Quantity
_____	_____	_____	_____
_____	_____	_____	_____
_____	_____	_____	_____

Please immediately examine this product carefully. Any request for missing parts or damage replacement must be received within 90 days of your receipt of the product. Replacement, if available, will be honored within this time frame. Parts will not be available for items arriving fully assembled. We do not recommend modifying product(s) and we are not responsible for any damages due to product modification(s). If damages or missing parts are not reported within 90 days of your receipt, we are under no obligation to provide parts or replacement merchandise.

Please contact Southern Enterprises at 800-633-5096 or in Dallas 972-869-0111/ 9am – 4pm Mon-Fri Central Time if you have product issues or email us at service@seidal.com. Please ask for customer service representative for issues involving damages or replacement parts. Please ask for technical assistance representative for any issues with product and assembly/construction.

Please contact the retailer that you purchased from for returns.



Southern
ENTERPRISES

Customer Service 1-800-633-5096
service@seidal.com
Southern Enterprises, Inc.
600 Freeport Parkway, Suite 200
Coppell, Texas 75019



CAUTION

Max shelf load capacity is achieved by mounting screw into studs or cement walls.

If mounting to sheet rock (cavity wall) it is advisable to mount at least 1 screw (without anchor) directly to a wall stud or studs. However, do not leave either end of mounting bracket unsupported by at least one anchor. For hollow wall mounting, you can use any of the holes in the back plate to suit where you require the mounting screws positioned.

Note: Pipe bracket has a built-in safety design feature. Pipes have a slight upward angle to prevent floating shelf from fogging when shelf is loaded. Weight ratings are E.D.L. (evenly distributed load).