

CM862200TX

Hendrik Apothecary Console

Cabinet

Assembly Instructions



**Southern**  
**ENTERPRISES**

For assistance with assembly contact:

Southern Enterprises Inc.

Customer Service 1-800-633-5096

[service@seidal.com](mailto:service@seidal.com)

[www.seidal.com](http://www.seidal.com)

PO#:

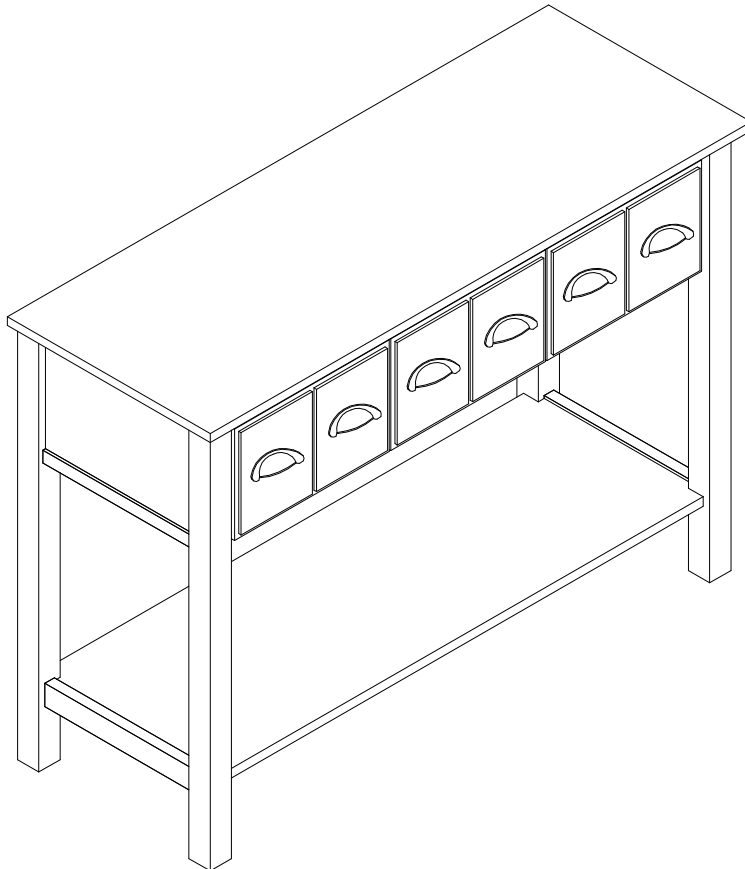







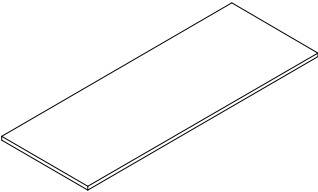
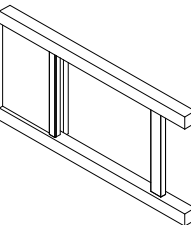
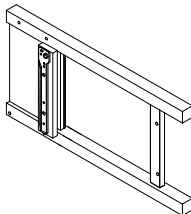
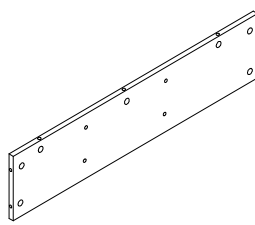
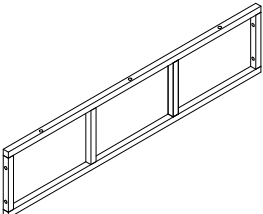
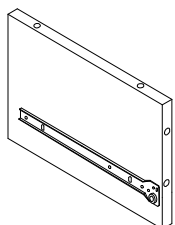
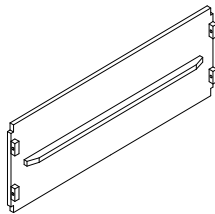
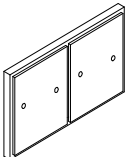
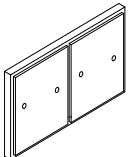
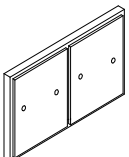
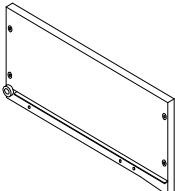
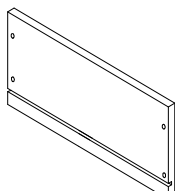

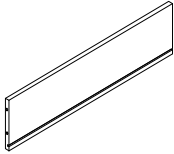
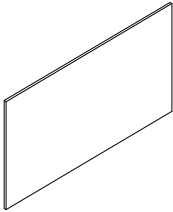
# Hendrik Apothecary Console

## Parts List

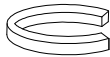
Please check packaging for all parts and hardware before discarding. Unpack and lay parts on clean, padded surface like carpet or blanket. Check that you have all parts indicated. Call customer service if hardware is missing. Before beginning assembly, carefully study the diagrams below and sort your hardware according to the pictures. Using the incorrect hardware will cause damage.

1  Top Panel	Quantity of 1	2  Left Side Panel	Quantity of 1	3  Right Side Panel	Quantity of 1
4  Back Panel	Quantity of 1	5  Front Panel	Quantity of 1	6  Middle Panel	Quantity of 2
7  Bottom Panel	Quantity of 1	8  Left Drawer Front	Quantity of 1	9  Middle Drawer Front	Quantity of 1
10  Right Drawer Front	Quantity of 1	11  Left Drawer Side Panel	Quantity of 3	12  Right Drawer Side Panel	Quantity of 3

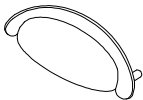
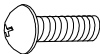
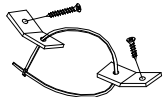
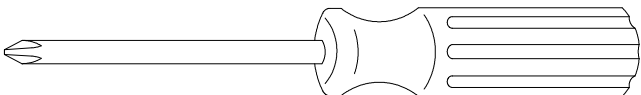
<p>13 Quantity of 3</p>  <p>Drawer Back Panel</p>	<p>14 Quantity of 3</p>  <p>Drawer Bottom Panel</p>	<p>A Quantity of 23</p>  <p>Cam Bolt</p>
<p>B Quantity of 23</p>  <p>Cam Lock</p>	<p>C Quantity of 11</p>  <p>Bolt Dia. 1/4x1-1/4" L</p>	<p>D Quantity of 4</p>  <p>Spring Washer Dia. 1/4"</p>
<p>E Quantity of 4</p>  <p>Flat Washer Dia. 1/4"x3/4"</p>	<p>F Quantity of 1</p>  <p>Allen Wrench</p>	<p>G Quantity of 24</p>  <p>Screw Dia. 5/32" x 1L</p>
<p>H Quantity of 6</p>  <p>Knob</p>	<p>I Quantity of 12</p>  <p>Bolts Dia. 5/32" x 1-1/8"L</p>	<p>J Quantity of 2</p>  <p>Anti-tipping hardware</p>
<p><b>Care and Cleaning Instructions:</b> Before using, wipe with a clean, dry cloth. Periodically apply furniture wax to renew the finish. Avoid rubbing or scratching the surface with rough or abrasive objects.</p>		<p>For replacement parts or questions, please call Customer Service at 1-800-633-5096.</p>
<p><b>Assembly Tool Required</b> <b>No.2 Phillips Screwdriver</b> <b>(Not Included)</b></p>		

# Hendrik Apothecary Console

## Assembly Instructions

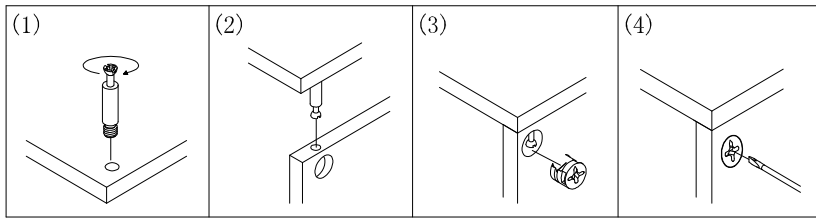

"Please do not over tighten cambolts. Please stop when you feel tight"

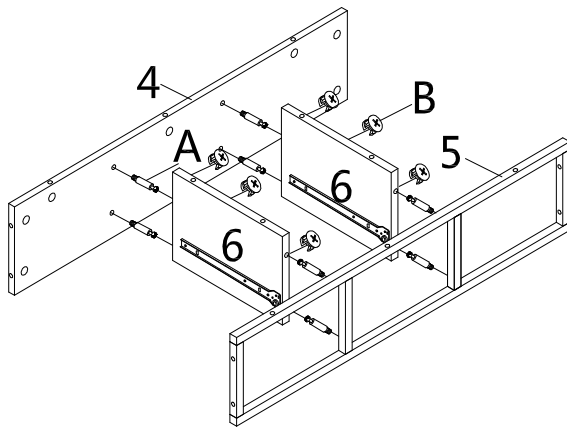

Figure 1

Start with finger to help align Cam Bolts before using screwdriver.

Insert Cam Locks **(B)** into corresponding holes on Middle Panel **(6)**.

Screw Cam Bolts **(A)** into threaded holes on Back Panel **(4)** and Front Panel **(5)**.

Attach Back Panel **(4)** and Front Panel **(5)** to Middle Panel **(6)** by inserting Cam Bolts **(A)** into corresponding holes until all panels meet.

Tighten Cam Bolts **(A)** by rotating Cam Locks **(B)** clockwise using Phillips screwdriver.

Insert Cam Locks **(B)** into corresponding holes on Back Panel **(4)**.

Screw Cam Bolts **(A)** into threaded holes on Left Side Panel **(2)** and Right Side Panel **(3)**.

Attach Left Side Panel **(2)** and Right Side Panel **(3)** to Back Panel **(4)** by inserting Cam Bolts **(A)** into corresponding holes until all panels meet.

Tighten Cam Bolts **(A)** by rotating Cam Locks **(B)** clockwise using Phillips screwdriver.

Use Bolts **(C)** to connect Side Panels **(2/3)** to Front Frame **(5)**.

Use Bolts **(C)** with Flat Washers **(E)** and Spring Washers **(D)** to connect Side Panels **(2/3)** to Bottom **(7)**.

Tighten Bolts **(C)** with Allen Wrench **(8)**.

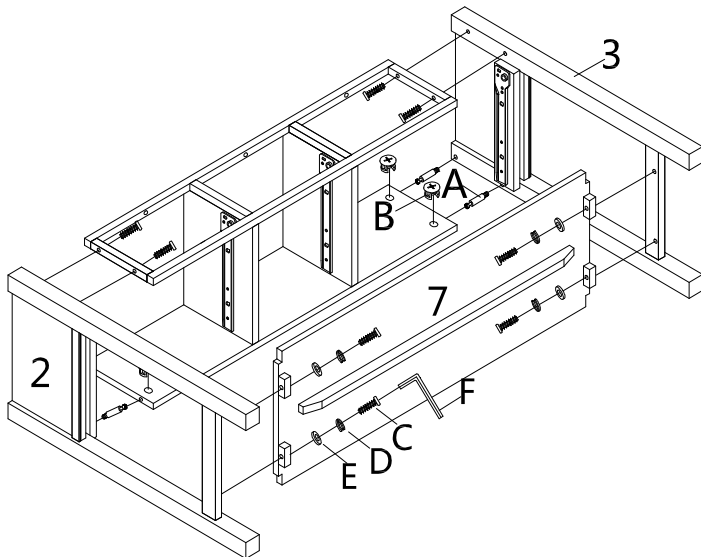

Figure 2

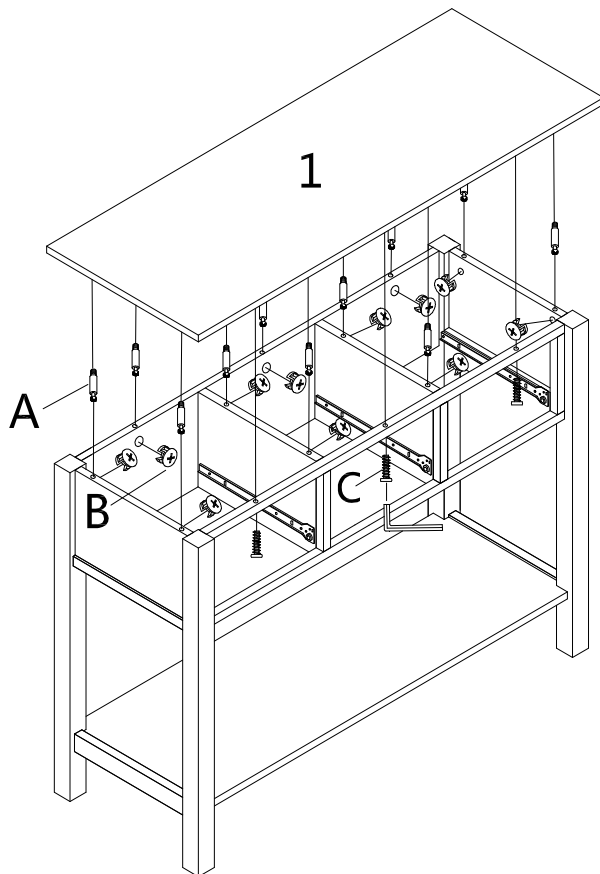

Figure 3

Insert Cam Locks **(B)** into corresponding holes on Left Side Panel **(2)**, Right Side Panel **(3)**, Middle Panel **(6)** and Back Panel **(4)**.

Screw Cam Bolts **(A)** into threaded holes on Top Panel **(1)**.

Attach Top Panel **(1)** to Left Side Panel **(2)**, Right Side Panel **(3)**, Middle Panel **(6)** and Back Panel **(4)** by inserting Cam Bolts **(A)** into corresponding holes until all panels meet.

Tighten Cam Bolts **(A)** by rotating Cam Locks **(B)** clockwise using Phillips screwdriver.

Use Bolts **(C)** to connect Top Panel **(1)** to Front Frame **(5)**.

Tighten Bolts **(C)** using Allen Wrench **(F)**.

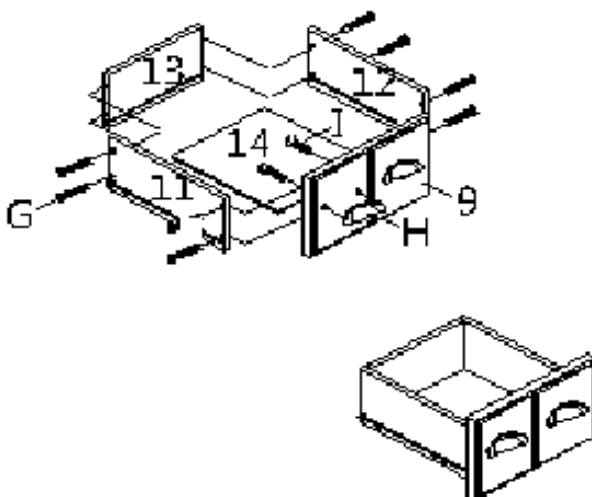

Figure 4

Start with finger to help align Screws.

Attach Drawer Side Panels **(11/12)** to Drawer Back Panel **(13)** using Screws **(G)**.

Tighten Screws **(G)** with Phillips screwdriver.

Insert Drawer Bottom Panel **(14)** into the grooves of Panels **(11/12/13)**.

Attach Drawer Front Panel **(9)** to the assembled unit using Screws **(G)**.

Finally, attach Knobs **(H)** to the Drawer Front Panel **(9)** using Bolts **(I)**.

Tighten Bolts **(I)** with Phillips screwdriver.

Repeat step for additional drawers using Drawer Front Panels **(8/10)**.

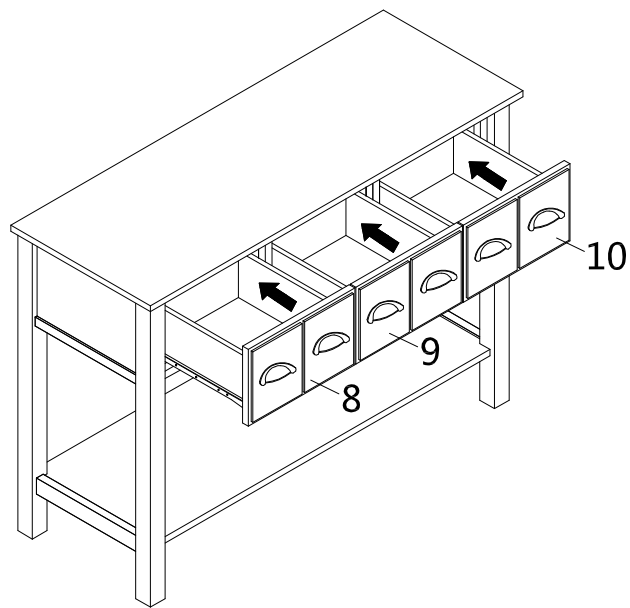

Insert drawers into assembled unit as shown.

Make sure all slides glide smoothly in and out.

Figure 4

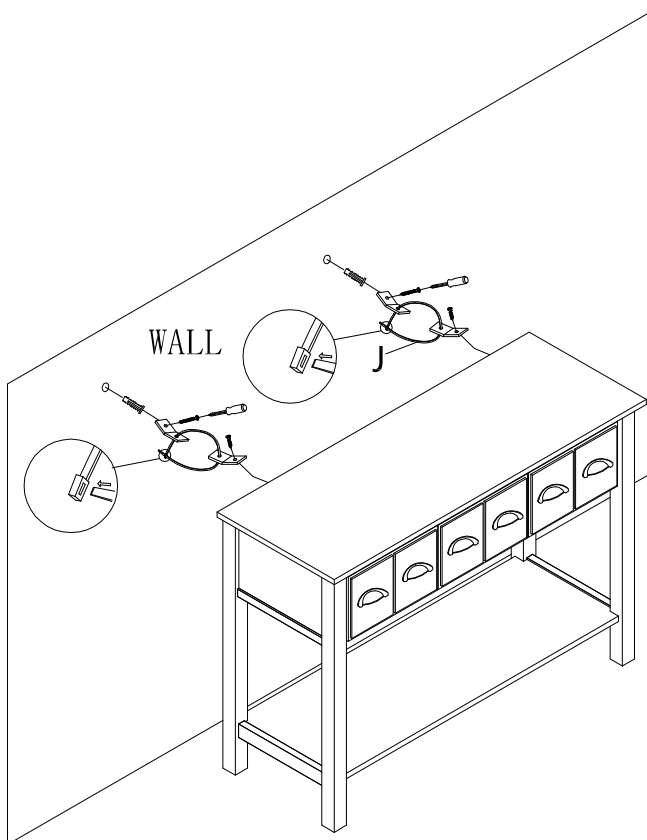

Attach Brackets (J) to back panel using Screws (J).

Tighten Screws (J) using Philips screwdriver. Mark two desired locations in the same distance as the Brackets (7) located on the back of the unit onto the wall and drill two 3/16" holes for each Bracket (J).

Insert Plastic Anchors (J) into the holes for each Bracket (J) on wall as shown. Use a hammer to insert plastic anchors until they are flush with wall.

Then, attach Brackets (J) onto wall using Screws (J).

Tighten Screws (J) using Philips screwdriver.

Move this item close to the wall Brackets (J) and tie in all Brackets (J) together with Plastic Straps (J) as shown in diagram.

**Anti-tipping hardware must be used for this product to avoid tipping and injury.**

Figure 5

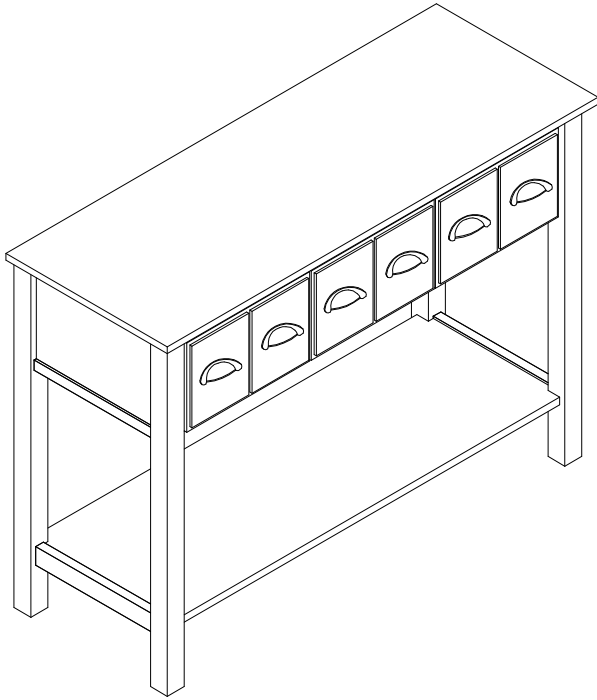

Now your Hendrik apothecary console is ready to use.

Figure 7

# Parts Replacement Form

## Customer Information

Name \_\_\_\_\_

Address \_\_\_\_\_

City/State/Zip Code \_\_\_\_\_

Phone Number \_\_\_\_\_

Please indicate where you purchased this item: Store/Website/Catalog

\_\_\_\_\_

Please indicate color/size/style number:

\_\_\_\_\_

Style No	Parts Letter	Parts Description	Quantity Needed
_____	_____	_____	_____
_____	_____	_____	_____
_____	_____	_____	_____

Please immediately examine this product carefully. Any request for missing parts or damage replacement must be received within 90 days of your receipt of the product. Replacement, if available, will be honored within this time frame. Parts will not be available for items arriving fully assembled. We do not recommend modifying product(s) and we are not responsible for any damages due to product modification(s). If damages or missing parts are not reported within 90 days of your receipt, we are under no obligation to provide parts or replacement merchandise.

For product issues, please contact Southern Enterprises at 800-633-5096 (toll-free) / 972-869-0111 (Dallas) Mon-Fri 9am – 4pm CST, or email us at [service@seidal.com](mailto:service@seidal.com). Please ask for customer service representative for issues involving damages or replacement parts. Please ask for technical assistance representative for any issues with product and assembly/construction.

Please contact the retailer that you purchased from for returns.



**Southern**  
ENTERPRISES

Customer Service: 1-800-633-5096

[service@seidal.com](mailto:service@seidal.com)

Southern Enterprises, Inc.

600 Freepoint Parkway, Suite 200

Coppell, Texas 75019