

CK012400TX

**Blackwashed Water Hyacinth
Storage Trunk w/Wood Top
Assembly Instructions**



**Southern
ENTERPRISES**

For assistance with assembly contact:
Southern Enterprises Inc.
Customer Service 1-800-633-5096
service@seidal.com
www.seidal.com

PO#12981

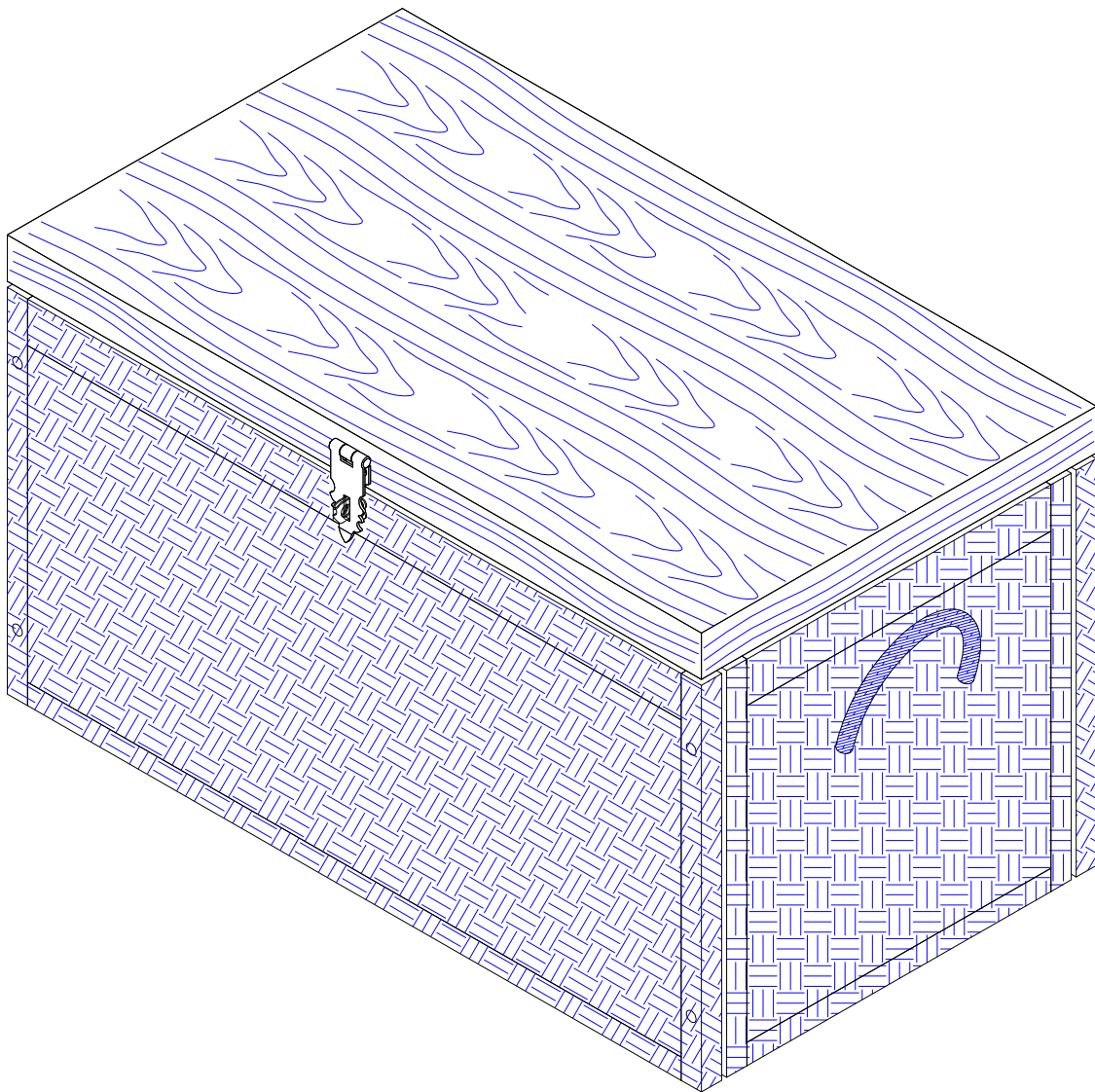

CK012400TX

Blackwashed Water Hyacinth Storage Trunk w/Wood Top

Parts List

Please check packaging for all parts and hardware before discarding. Unpack and lay parts on clean, padded surface like carpet or blanket. Check that you have all parts indicated. Call customer service if hardware is missing. Before beginning assembly, carefully study the diagrams below and sort your hardware according to the pictures. Using the incorrect hardware will cause damage.

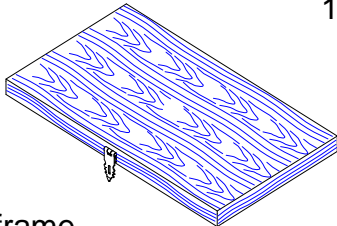
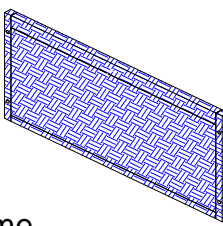
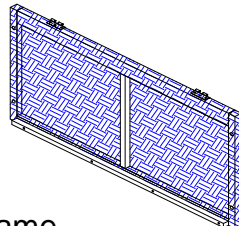
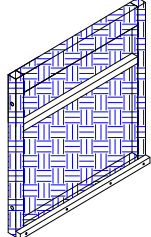
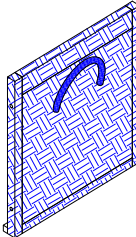
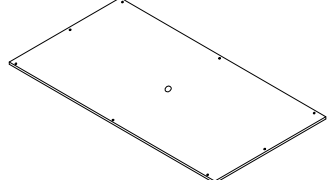
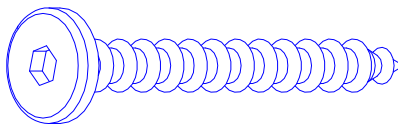
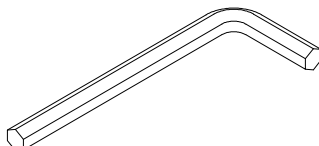
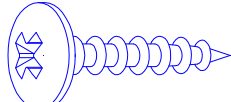
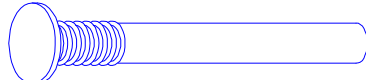
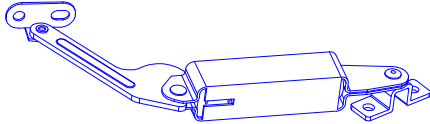
<p>A 1pc</p>  <p>top frame</p>	<p>B 1pc</p>  <p>front frame</p>	<p>C 1pc</p>  <p>back frame</p>
<p>D 1pc</p>  <p>left frame</p>	<p>E 1pc</p>  <p>right frame</p>	<p>F 1pc</p>  <p>bottom panel</p>
<p>1 8pcs</p>  <p>allen screw</p>	<p>2 1pc</p>  <p>allen key</p>	<p>3 16pcs</p>  <p>round screw</p>
<p>4 4pcs</p>  <p>bolt</p>	<p>5 2pcs</p>  <p>safety hinge</p>	

Care and Cleaning Instructions:

Before using, wipe with a clean, dry cloth. Periodically apply furniture wax to renew the finish. Avoid rubbing or scratching the surface with rough or abrasive objects.

For replacement parts or questions, please call customer service at 1-800-633-5096.

Assembly Tool Required
No.2 Phillips Screwdriver

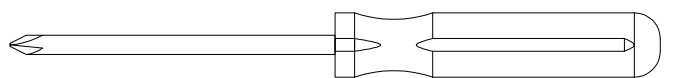

CK012400TX

Blackwashed Water Hyacinth Storage Trunk w/Wood Top

Top

Assembly Instructions

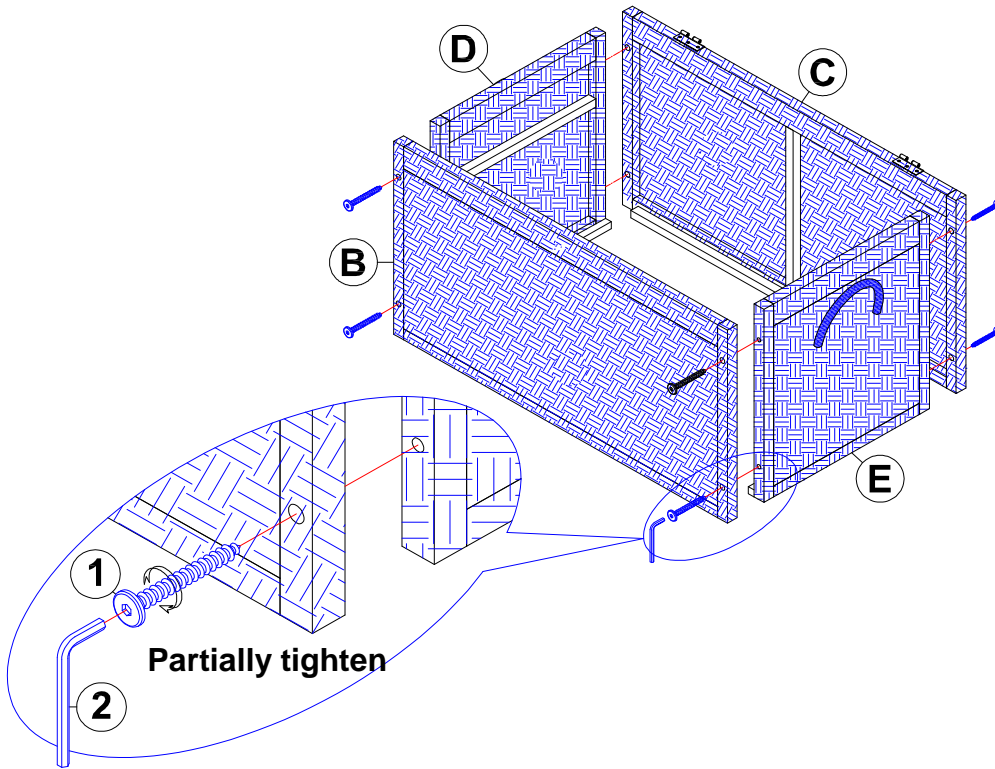

Step 1:

Attach front frame (B) and back frame (C) to left frame (D) and right frame (E) with 8pcs allen screw (1).

Using allen key (2), partially tighten all allen screws (1) as shown.

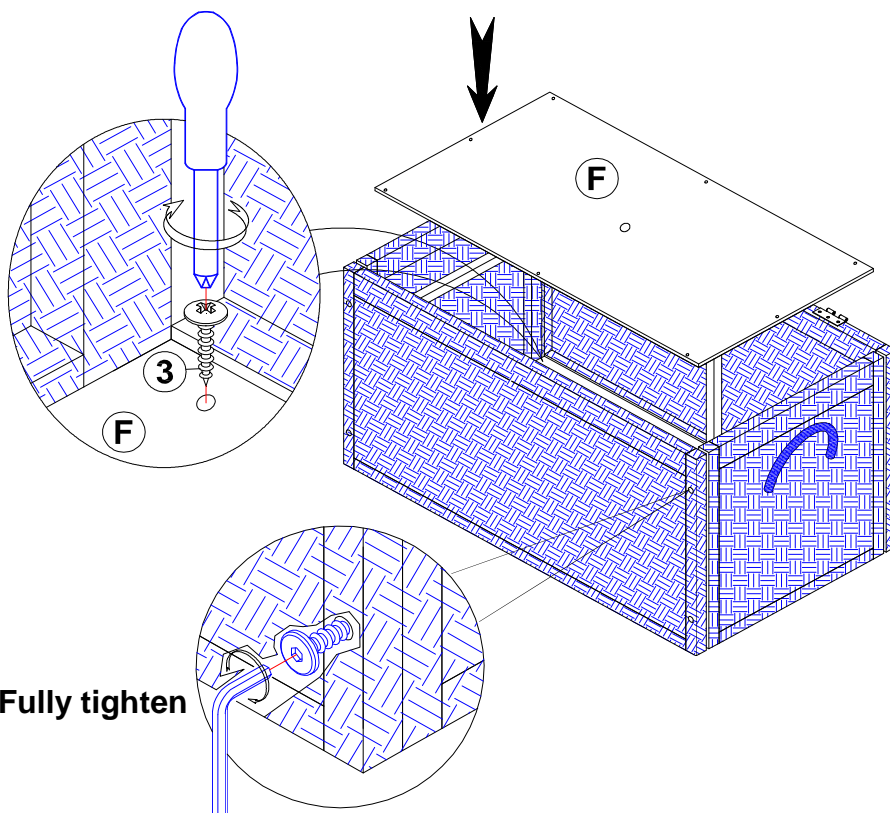

Step 2:

Attach bottom panel (F) inside the trunk.

Fully tighten all allen screws.

Using screw driver, tighten 8pcs round screws (3) as shown.

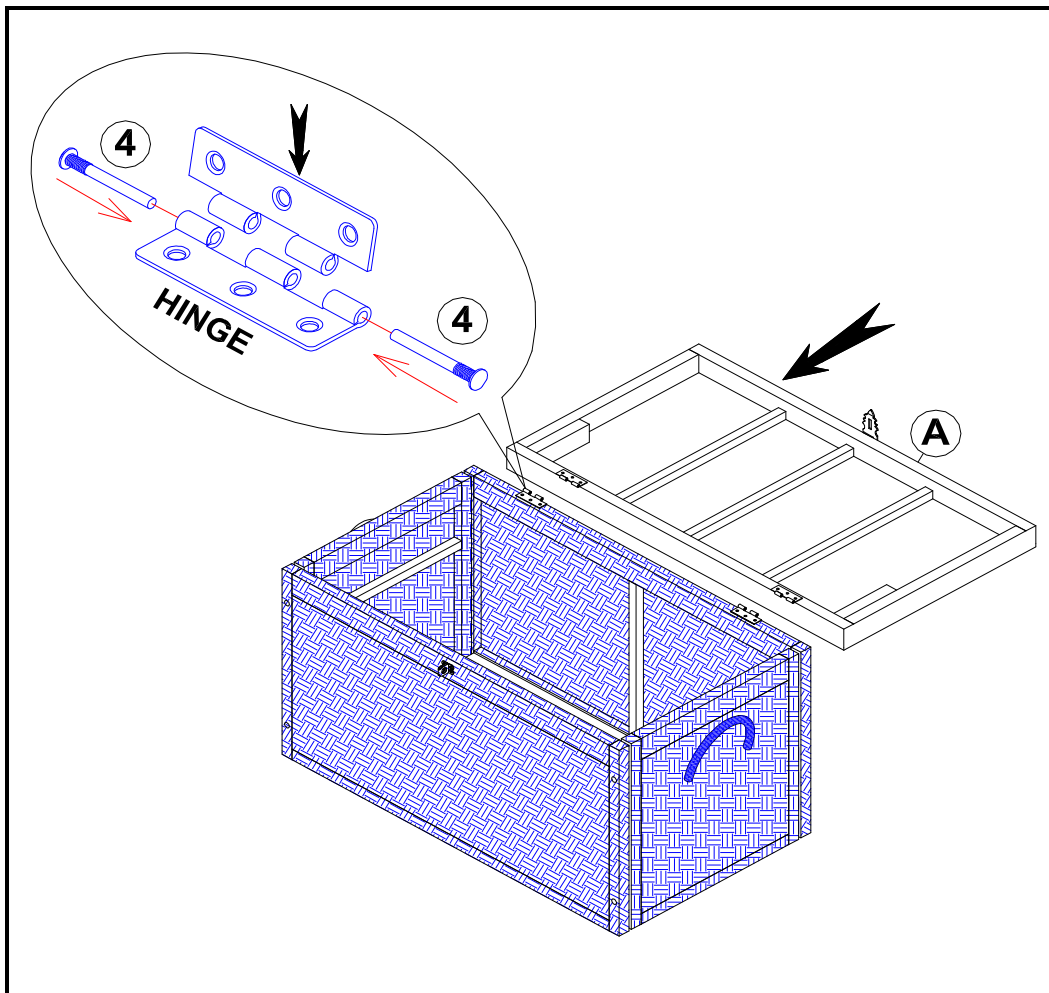

Step 3:

Attach top frame (A) to back frame (C) by attaching the pre-installed hinges on the top frame to the hinges on the back frame using 4pcs bolt (4) as shown.

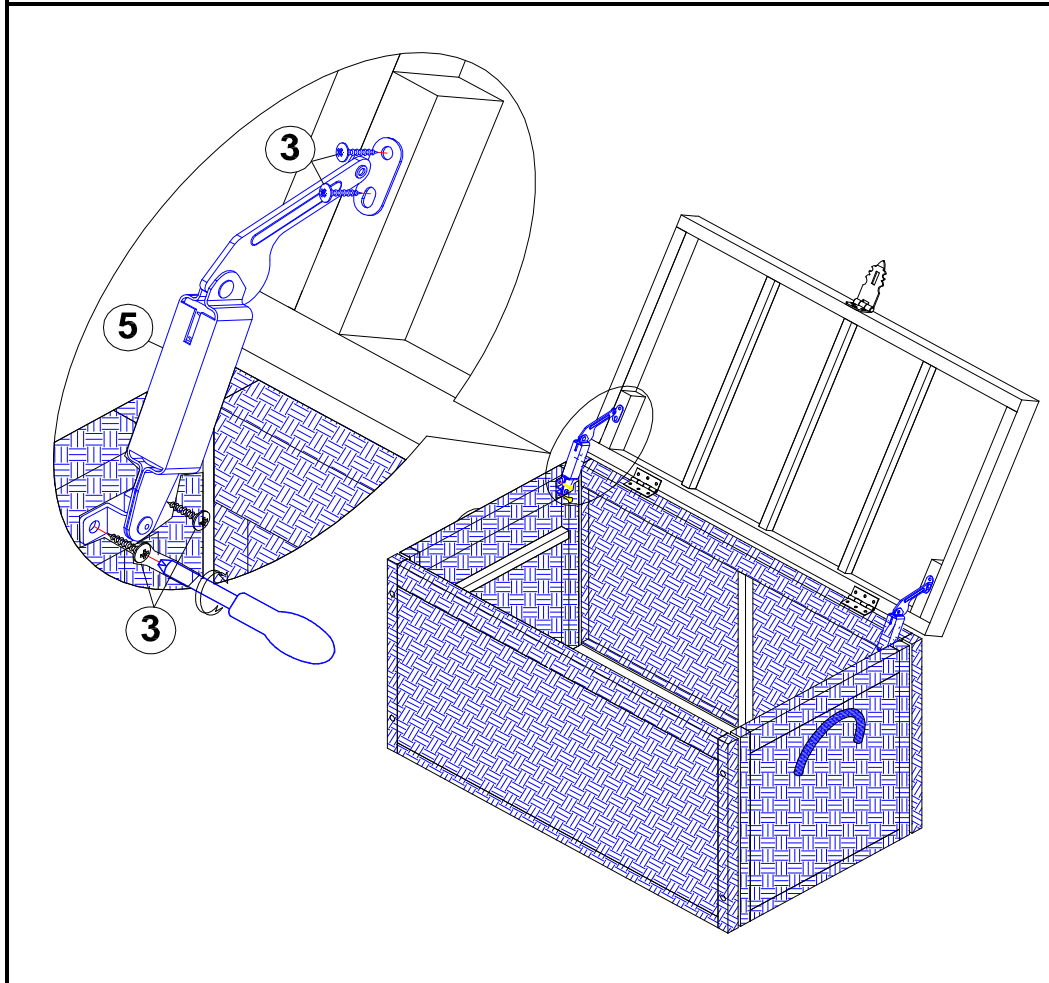

Step 4:

Attach 2pcs safety hinges (5) to pre-drilled holes on left frame (D), right frame (E), and top frame (1) using screwdriver. Tighten 8pcs round screws (3) for the safety hinges as shown.

ASSEMBLY IS COMPLETE

Parts Replacement Form

Customer Information

Name _____

Address _____

City/State/Zip Code _____

Phone Number _____

Please indicate where you purchased this item: Store/Website/Catalog

Please indicate color/size/style number:

Style No	Parts Letter	Parts Description	Quantity Needed
_____	_____	_____	_____
_____	_____	_____	_____
_____	_____	_____	_____

Please immediately examine this product carefully. Any request for missing parts or damage replacement must be received within 90 days of your receipt of the product. Replacement, if available, will be honored within this time frame. Parts will not be available for items arriving fully assembled. We do not recommend modifying product(s) and we are not responsible for any damages due to product modification(s). If damages or missing parts are not reported within 90 days of your receipt, we are under no obligation to provide parts or replacement merchandise.

Please contact Southern Enterprises at 800-633-5096 or in Dallas 972-869-0111/ 9am – 4pm Mon-Fri Central time if you have product issues or email us at service@seidal.com. Please ask for customer service representative for issues involving damages or replacement parts. Please ask for technical assistance representative for any issues with product and assembly/construction.

Please contact the retailer that you purchased from for returns.



Southern
ENTERPRISES

Customer Service 1-800-633-5096
service@seidal.com
Southern Enterprises, Inc.
600 Freeport Parkway, Suite 200
Coppell, Texas 75019